

SAMSUNG

FULL MANUAL

HW-T400

Imagine the possibilities

Thank you for purchasing this Samsung product.

To receive more complete service, please register
your product at www.samsung.com/register

SAFETY INFORMATION









SAFETY WARNINGS

TO REDUCE THE RISK OF ELECTRIC SHOCK, DO NOT REMOVE THE COVER (OR BACK).

NO USER-SERVICEABLE PARTS ARE INSIDE.

REFER SERVICING TO QUALIFIED SERVICE PERSONNEL.

Refer to the table below for an explanation of symbols which may be on your Samsung product.

	<p style="text-align: center;">CAUTION RISK OF ELECTRIC SHOCK. DO NOT OPEN.</p>	
	<p>This symbol indicates that high voltage is present inside. It is dangerous to make any kind of contact with any internal part of this product.</p>	
	<p>This symbol indicates that this product has included important literature concerning operation and maintenance.</p>	
	<p>Class II product : This symbol indicates that it does not require a safety connection to electrical earth (ground). If this symbol is not present on a product with a power cord, the product MUST have a reliable connection to protective earth (ground).</p>	
	<p>AC voltage : This symbol indicates that the rated voltage marked with the symbol is AC voltage.</p>	
	<p>DC voltage : This symbol indicates that the rated voltage marked with the symbol is DC voltage.</p>	
	<p>Caution, Consult instructions for use : This symbol instructs the user to consult the user manual for further safety related information.</p>	

WARNING

- To reduce the risk of fire or electric shock, do not expose this appliance to rain or moisture.

CAUTION

- TO PREVENT ELECTRIC SHOCK, MATCH WIDE BLADE OF PLUG TO WIDE SLOT, FULLY INSERT.
- This apparatus shall always be connected to a AC outlet with a protective grounding connection.
- To disconnect the apparatus from the mains, the plug must be pulled out from the mains socket, therefore the mains plug shall be readily operable.
- Do not expose this apparatus to dripping or splashing. Do not put objects filled with liquids, such as vases on the apparatus.
- To turn this apparatus off completely, you must pull the power plug out of the wall socket. Consequently, the power plug must be easily and readily accessible at all times.

Wiring the Main Power Supply Plug (UK Only)

IMPORTANT NOTICE

The mains lead on this equipment is supplied with a moulded plug incorporating a fuse. The value of the fuse is indicated on the pin face of the plug and if it requires replacing, a fuse approved to BS1362 of the same rating must be used. Never use the plug with the fuse cover removed. If the cover is detachable and a replacement is required, it must be of the same colour as the fuse fitted in the plug. Replacement covers are available from your dealer. If the fitted plug is not suitable for the power points in your house or the cable is not long enough to reach a power point, you should obtain a suitable safety approved extension lead or consult your dealer for assistance.

However, if there is no alternative to cutting off the plug, remove the fuse and then safely dispose of the plug. Do not connect the plug to a mains socket as there is a risk of shock hazard from the bared flexible cord. Never attempt to insert bare wires directly into a mains socket. A plug and fuse must be used at all times.

IMPORTANT

The wires in the mains lead are coloured in accordance with the following code:– BLUE = NEUTRAL BROWN = LIVE As these colours may not correspond to the coloured markings identifying the terminals in your plug, proceed as follows:– The wire coloured BLUE must be connected to the terminal marked with the letter N or coloured BLUE or BLACK. The wire coloured BROWN must be connected to the terminal marked with the letter L or coloured BROWN or RED.

WARNING : DO NOT CONNECT EITHER WIRE TO THE EARTH TERMINAL WHICH IS MARKED WITH THE LETTER E OR BY THE EARTH SYMBOL , OR COLOURED GREEN OR GREEN AND YELLOW.

PRECAUTIONS

1. Ensure that the AC power supply in your house complies with the power requirements listed on the identification sticker located on the bottom of your product. Install your product horizontally, on a suitable base (furniture), with enough space around it for ventilation (7~10 cm). Make sure the ventilation slots are not covered. Do not place the unit on amplifiers or other equipment which may become hot. This unit is designed for continuous use. To fully turn off the unit, disconnect the AC plug from the wall outlet. Unplug the unit if you intend to leave it unused for a long period of time.
2. During thunderstorms, disconnect the AC plug from the wall outlet. Voltage peaks due to lightning could damage the unit.
3. Do not expose the unit to direct sunlight or other heat sources. This could lead to overheating and cause the unit to malfunction.
4. Protect the product from moisture (i.e. vases), and excess heat (e.g. a fireplace) or equipment creating strong magnetic or electric fields. Unplug the power cable from the AC wall socket if the unit malfunctions. Your product is not intended for industrial use. It is for personal use only. Condensation may occur if your product has been stored in cold temperatures. If transporting the unit during the winter, wait approximately 2 hours until the unit has reached room temperature before using.
5. The battery used with this product contains chemicals that are harmful to the environment. Do not dispose of the battery in the general household trash. Do not expose the battery to excess heat, direct sunlight, or fire. Do not short circuit, disassemble, or overheat the battery. Danger of explosion if the battery is replaced incorrectly. Replace only with the same or equivalent type.

ABOUT THIS MANUAL

The user manual has two parts: this simple paper USER MANUAL and a detailed FULL MANUAL you can download.



USER MANUAL

See this manual for safety instructions, product installation, components, connections, and product specifications.



FULL MANUAL

You can access the FULL MANUAL on Samsung's on-line customer support centre by scanning the QR code on the left. To see the manual on your PC or mobile device, download the manual in document format from Samsung's website. (<http://www.samsung.com/support>)

Design and specifications are subject to change without prior notice.

CONTENTS

01	Checking the Components	6
	Inserting battery (AAA) into the Remote Control	6
02	Product Overview	7
	Front / Right Side Panel of the Soundbar	7
	Bottom Panel of the Soundbar	8
03	The Remote Control	9
	Using the Hidden Buttons (Buttons with more than one function)	10
	Adjusting the Soundbar volume with a TV remote control	12
04	Connecting the Soundbar	13
	Connecting Electrical Power	13

05	Connecting to a TV	14
	Connecting using an Optical Cable	14
	Connecting a TV or Bluetooth Device via Bluetooth	16
	Connecting a Soundbar to a mobile device via NFC function	17
06	Connecting an External Device	20
	Connecting using an Optical Cable	20
	Connecting using an Analogue Audio (AUX) Cable	21
07	Connecting a USB Storage Device	22
	Setting Repeat Play Options	23
08	System Initialise	25
09	Installing the Wall Mount (Optional)	26
	Installation Precautions	26
	Wall mount Components	26
10	Software Update	29
	Update Procedure	29
	When update fails	30
11	Troubleshooting	31
12	Licence	32
13	Open Source Licence Notice	32
14	Important Notes About Service	32
15	Specifications and Guide	33
	Specifications	33

01 CHECKING THE COMPONENTS

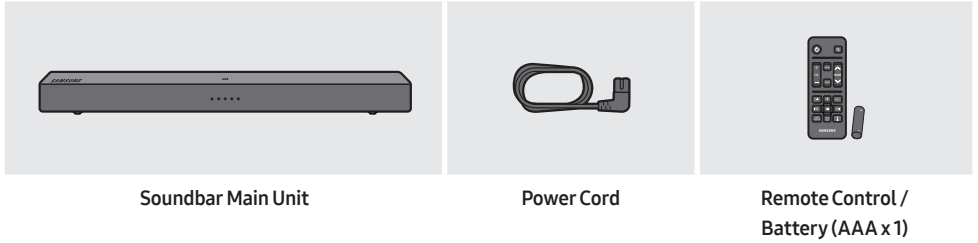

- User Manual / Warranty Card / Regulatory Guide (Not available in some locations).
- For more information about the power supply and power consumption, refer to the label attached to the product. (Label : Bottom of the Soundbar Main Unit)
- To purchase additional components or optional cables, contact a Samsung Service Centre or Samsung Customer Care.
- The appearance of the accessories may differ slightly from the illustrations above.

Inserting battery (AAA) into the Remote Control

Match the polarity of the battery to the symbols on the battery compartment.

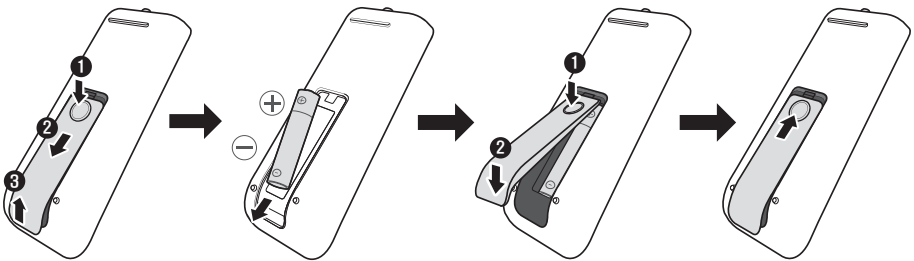

02 PRODUCT OVERVIEW

Front / Right Side Panel of the Soundbar

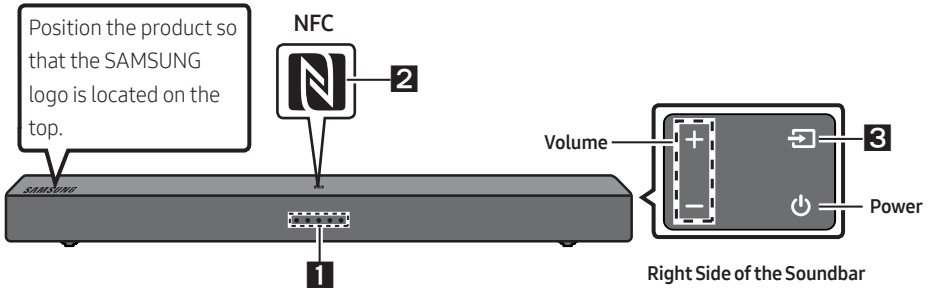

The LED Indicator flashes, glows, or changes colour depending on the Soundbar's current mode or status. The colour of the LED indicator and the number of lights indicate the active mode as described below.

(W) White LED (B) Blue LED (R) Red LED (G) Green LED

1 LED indicator

Mode	Remote control Button	LED indicator
D.IN		(W) ○ ○ ○ ○
Bluetooth		(B) ○ ○ ○ ○ Connected status
		Slow-Blinking (B) ○ ○ ○ ○ Disconnected status
Bluetooth pairing		Fast-Blinking (B) ○ ○ ○ ○
AUX		(W) (W) ○ ○ ○
USB		(W) (W) (W) ○ ○

2	NFC Logo	You can activate your Bluetooth connection by placing your phone in the NFC detection area of the Soundbar.
3	Source	Selects the source input mode. (D.IN / Bluetooth / AUX / USB) <ul style="list-style-type: none"> To turn on "Bluetooth pairing" mode, change the source to "Bluetooth" mode and then press and hold the  button for more than 5 seconds.

Bottom Panel of the Soundbar

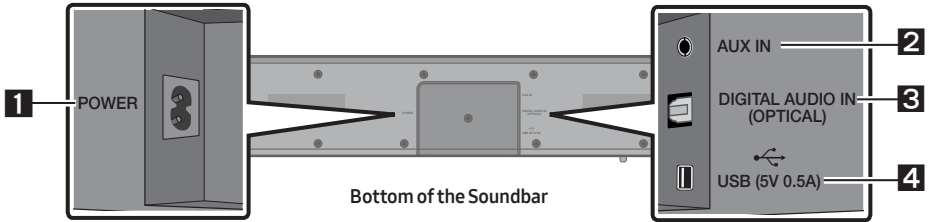

1	POWER	Connect the Soundbar's AC power cord.
2	AUX	Connect to the Analogue output of an external device.
3	D.IN	Connect to the digital (optical) output of an external device.
4	USB	Connect a USB device here to play music files on the USB device through the Soundbar.





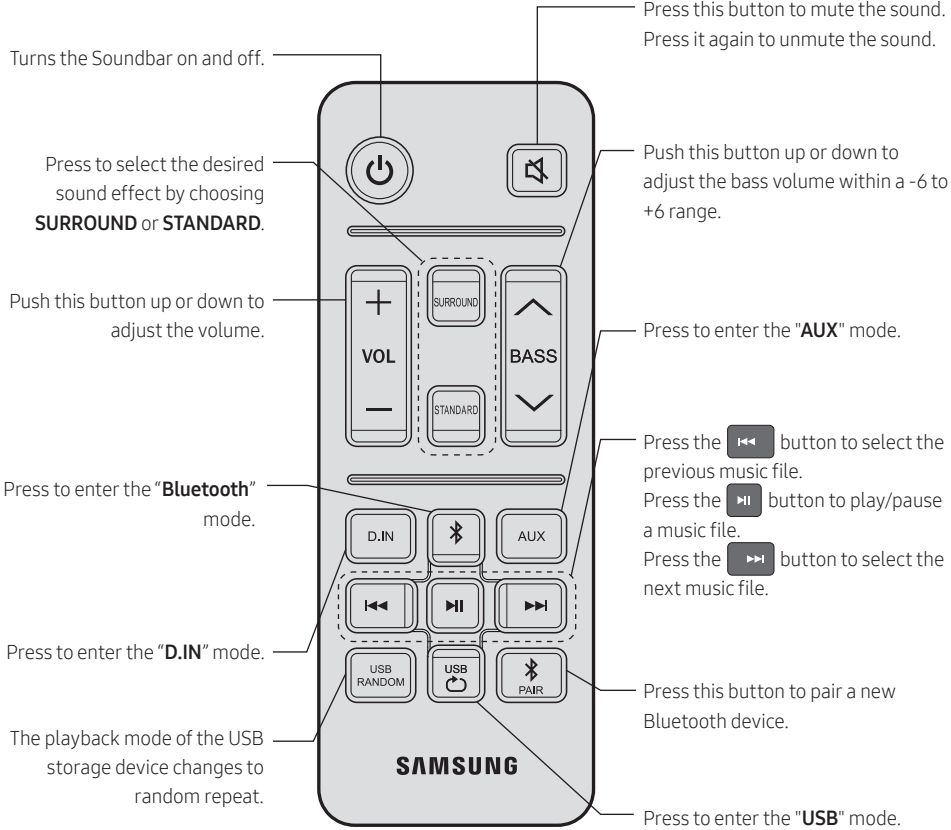

- When you plug in the AC cord, the power button will begin working in 4 to 6 seconds.
- When you turn on this unit, there will be a 4 to 5 second delay before it produces sound.
- If you want to enjoy sound only from the Soundbar, you must turn off the TV's speakers in the Audio Setup menu of your TV. Refer to the owner's manual supplied with your TV.
- When disconnecting the power cord from a wall outlet, pull the plug. Do not pull the cable.
- Do not connect this unit or other components to an AC outlet until all connections between components are complete.



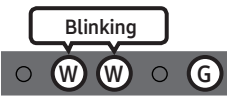
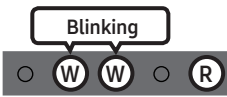
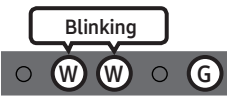
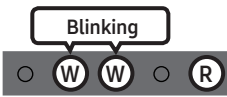
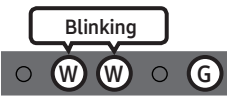
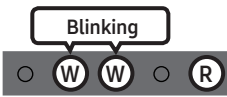

03 THE REMOTE CONTROL

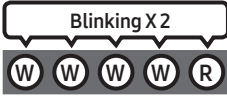
- The images, buttons, and functions of the remote control may differ depending on the model.

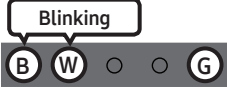
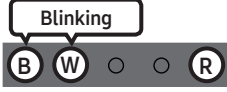

Using the Hidden Buttons (Buttons with more than one function)

Hidden Button		How to Use the Remote Control		
Remote Control Button	Function			
	Auto Power Down On/Off (AUX mode)	<ul style="list-style-type: none"> - D.IN / Bluetooth / USB / AUX Mode : If there is no audio signal for 18 minutes. - If there is no KEY input for 8 hours when the Audio (AUX) Cable is connected. (Auto Power Down function can be turned off only in that case.) - To turn off Auto Power Down function, while in "AUX" mode, press and hold the  button for 5 seconds. <div style="border: 1px solid black; padding: 5px; margin-top: 10px;"> <p style="text-align: center;">LED indicator</p> <table style="width: 100%; text-align: center;"> <tr> <td style="width: 50%;">  <p>Auto Power Down On</p> </td> <td style="width: 50%;">  <p>Auto Power Down Off</p> </td> </tr> </table> </div>	 <p>Auto Power Down On</p>	 <p>Auto Power Down Off</p>
	 <p>Auto Power Down On</p>	 <p>Auto Power Down Off</p>		
Initialise (Standby)	<p>Press the  button for 5 seconds in the standby power off station to trigger the system initial function.</p> <ul style="list-style-type: none"> - This operation will not clear Bluetooth paired history. <div style="border: 1px solid black; padding: 5px; margin-top: 10px;"> <p style="text-align: center;">LED indicator</p>  </div>			
	TV remote control On/Off (Standby)	For detailed information about TV remote control, please see "Adjusting the Soundbar volume with a TV remote control" on page 12.		
	TV Connect (Bluetooth mode)	For detailed information about TV Connect, please see "Disconnecting the Soundbar from the TV" on page 17.		

	<p>Bluetooth Power On/Off</p>	<p>Press the  button for 5 seconds in the power on station to trigger the Bluetooth Power On/Off function.</p> <div data-bbox="434 177 1021 360" style="border: 1px solid black; padding: 5px;"> <p style="text-align: center;">LED indicator</p> <div style="display: flex; justify-content: space-around;"> <div style="text-align: center;">  <p>Bluetooth Power On</p> </div> <div style="text-align: center;">  <p>Bluetooth Power Off</p> </div> </div> </div>
	<p>Auto Power Link On/Off</p>	<p>For detailed information about Auto Power Link On/Off function, please see "Auto Power Link" on page 15.</p>







Adjusting the Soundbar volume with a TV remote control

If you have a Samsung TV, you can adjust the Soundbar's volume using the IR remote control that came with your Samsung TV.

First use the TV menu to set the TV audio on your Samsung TV to external speakers, then use your Samsung remote to control the Soundbar's volume. For more information, see the TV's user manual.

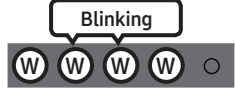
The default mode for this function is control by a Samsung TV.

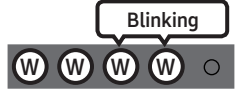
1. If your TV is not a Samsung TV and you want your TV's remote to control the Soundbar's volume, you can change the settings of this function by pressing and holding the **BASS**  button repeatedly. To have your TV's remote adjust the Soundbar's volume, follow Steps 1 through 3 below.
2. If you want to turn off this function completely, follow Steps 1 and 2.

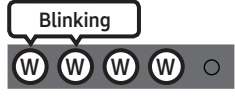
	Mode	Remote control Button	LED indicator
1.	Turn off		
2.	"Off" mode		
3.	"All TV" mode		
4.	"Samsung TV" mode (Default mode)		

- Each time you press the **BASS**  button and hold it for 5 seconds, the mode switches in the following order: "Samsung TV" (Default mode) → "Off" → "All TV".
- The LED's blink for 3-4 seconds, then return to the standby power off mode.
- This function may not be available, depending on your TV's remote control.
- Manufacturers supporting this function: VIZIO, LG, Sony, Sharp, PHILIPS, PANASONIC, TOSHIBA, Hisense, RCA

04 CONNECTING THE SOUNDBAR

Connecting Electrical Power

- For information about the required electrical power and power consumption, refer to the label attached to the product. (Label : Bottom of the Soundbar Main Unit)

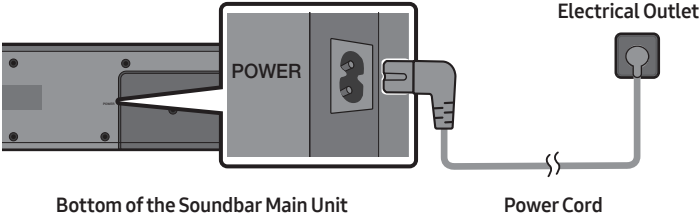

05 CONNECTING TO A TV

Hear TV sound from your Soundbar through wired or wireless connections.

- When the Soundbar is connected to selected Samsung TVs, you can control the Soundbar using the TV's remote control.
 - This feature is supported by 2017 and later Samsung Smart TVs that support Bluetooth when you connect the Soundbar to the TV using an optical cable.
 - This function also allows you to use the TV menu to adjust the sound field and various settings as well as the volume and mute.

Connecting using an Optical Cable

Step 1. Connect an Optical Cable

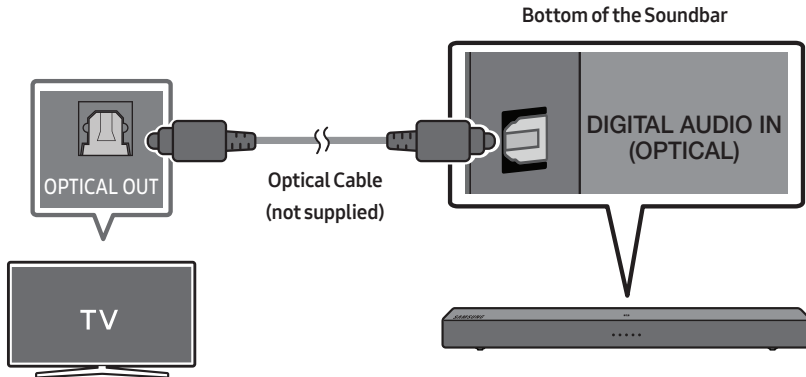

NOTE

- When the audio in a broadcast is encoded in Dolby Digital and the “Digital Output Audio Format” on your TV is set to PCM, we recommend that you change the setting to Dolby Digital. When the setting on the TV is changed, you will experience better sound quality. (The TV menu may use different words for Dolby Digital and PCM depending on the TV manufacturer.)

Step 2. Change the Soundbar's mode to D.IN

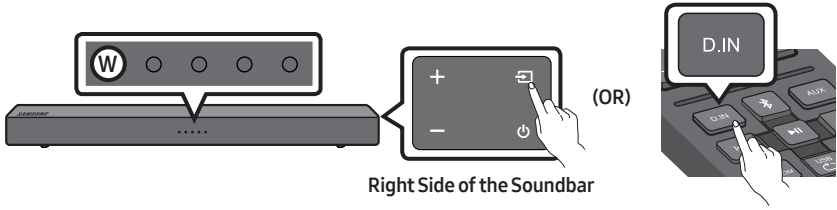



Auto Power Link

This Function automatically turns on the Soundbar when the TV is turned on if the Soundbar is connected to the TV by an Optical Cable (not supplied).

Press and hold the  button on the remote control for more than 5 seconds to toggle this function.

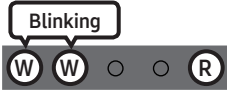
- Auto Power Link is set to ON by default.
- Depending on the connected device, Auto Power Link may not function.
- This function is only available in the "D.IN" mode.

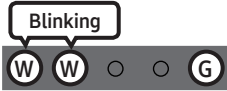
Mode	Remote control Button	LED indicator
OFF		
ON		

Connecting a TV or Bluetooth Device via Bluetooth

Step 1. Change the Soundbar mode to “Bluetooth Pairing”

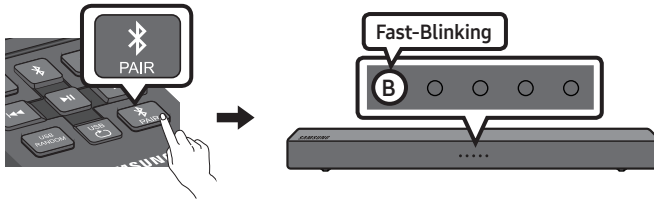

Step 2. Select the Soundbar in your TV's or Bluetooth device's Menu

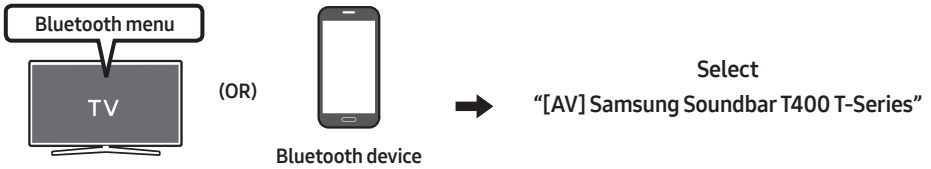

NOTE

- You cannot connect more than one TV or Bluetooth device at a time.

Step 3. Check the Soundbar's status

The blue LED should not be blinking once the Bluetooth connection is complete.

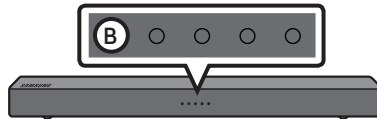





If the TV or device fails to connect

- If a previously connected Soundbar listing appears in the device list of your TV or Bluetooth device, delete it. (e.g. "[AV] Samsung Soundbar T400 T-Series")
- Then repeat steps 1 through 3.

Disconnecting the Soundbar from the TV

Press the  button on the right side panel or on the remote control and switch to any mode but **"Bluetooth"**.

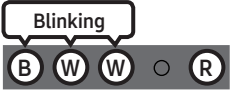
- Disconnecting takes time because the TV must receive a response from the Soundbar.
(The time required may differ, depending on the TV model.)
- To cancel the automatic Bluetooth connection between the Soundbar and TV, press and hold  button for 5 seconds in **"Bluetooth Ready"** mode. TV Connect is turned OFF.
- To turn TV Connect back on, press and hold the  button for 5 seconds with the Soundbar in **"Bluetooth Ready"** mode.
- TV Connect is set to ON by default.

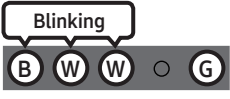
Mode	Remote control Button	LED indicator
TV Connect-OFF		
TV Connect-ON		

Connecting a Soundbar to a mobile device via NFC function

Step 1. Place your mobile device in the NFC detection area on top of the Soundbar

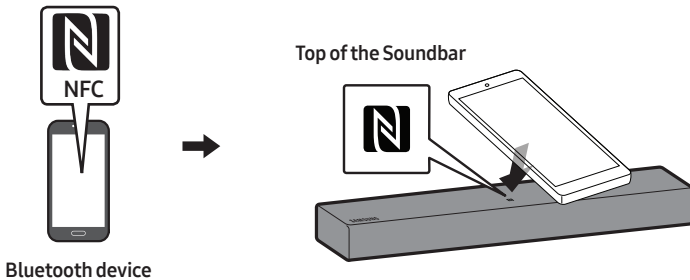

NOTES

- Make sure that your mobile device has the NFC function turned on and that the screen is active.
- Bluetooth connection is unavailable when NFC of the mobile device is in card emulation mode.

Step 2. Check the Soundbar's status

The blue LED should not be blinking once the Bluetooth connection is complete.

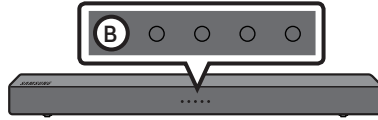

NOTES

- If asked for a PIN code when connecting a Bluetooth device, enter <0000>.
- The Soundbar automatically turns off after 18 minutes in the Ready state.
- The Soundbar may not perform Bluetooth search or connection correctly under the following circumstances:
 - If there is a strong electrical field around the Soundbar.
 - If several Bluetooth devices are simultaneously paired with the Soundbar.
 - If the Bluetooth device is turned off, not in place, or malfunctions.
- Electronic devices may cause radio interference. Devices that generate electromagnetic waves must be kept away from the Soundbar main unit - e.g., microwaves, wireless LAN devices, etc.
- The Soundbar supports SBC data (44.1kHz, 48kHz).
- Connect only to a Bluetooth device that supports the A2DP (AV) function.
- You cannot connect the Soundbar to a Bluetooth device that supports only the HF (Hands Free) function.
- Once you have paired the Soundbar to a Bluetooth device, selecting “[AV] Samsung Soundbar T400 T-Series” from the device’s scanned devices list will automatically change the Soundbar to “Bluetooth” mode.
 - Available only if the Soundbar is listed among the Bluetooth device’s paired devices.
(The Bluetooth device and the Soundbar must have been previously paired at least once.)
- The Soundbar cannot be paired to another Bluetooth device if already in Bluetooth mode and paired to a Bluetooth device.

Bluetooth Power On/Off

If a previously paired Bluetooth device tries to pair with the Soundbar when the Bluetooth Power function is on and the Soundbar is turned off, the Soundbar turns on automatically.

Press and hold the  button for more than 5 seconds in the power on station to trigger/shut off Bluetooth Power On function. For more information about Bluetooth Power On/Off, see page 11.

- Bluetooth Power function is set to On by default.

More About Bluetooth

Bluetooth is a technology that enables Bluetooth-compliant devices to interconnect easily with each other using a short wireless connection.

- A Bluetooth device may cause noise or malfunction, depending on usage, if:
 - A part of your body is in contact with the receiving/transmitting system of the Bluetooth device or the Soundbar.
 - It is subject to electrical variation from obstructions caused by a wall, corner, or office partition.
 - It is exposed to electrical interference from same frequency-band devices including medical equipment, microwave ovens, and wireless LANs.
- Pair the Soundbar with the Bluetooth device while they are close together.
- The further the distance between the Soundbar and Bluetooth device, the worse the quality is. If the distance exceeds the Bluetooth operational range, the connection is lost.
- In poor reception areas, the Bluetooth connection may not work properly.
- The Bluetooth connection only works when it is close to the unit. The connection will be automatically cut off if the Bluetooth device is out of range. Even within range, the sound quality may be degraded by obstacles such as walls or doors.
- This wireless device may cause electric interference during its operation.

06 CONNECTING AN EXTERNAL DEVICE

Connect to an external device via an optical cable or analogue cable to play the external device's sound through the Soundbar.

Connecting using an Optical Cable

Step 1. Connect using an Optical Cable

BD / DVD player / Set-top box /
Game console

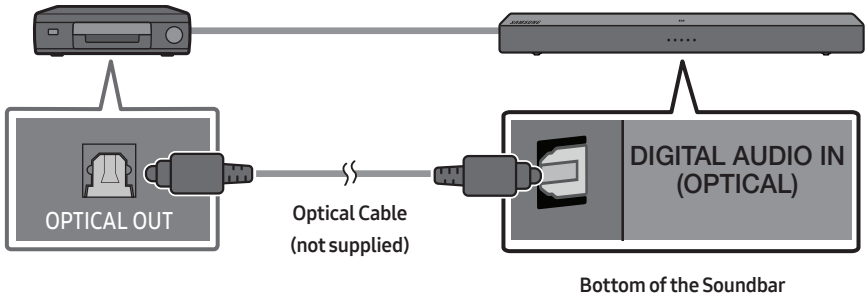

Step 2. Change the Soundbar's mode to D.IN

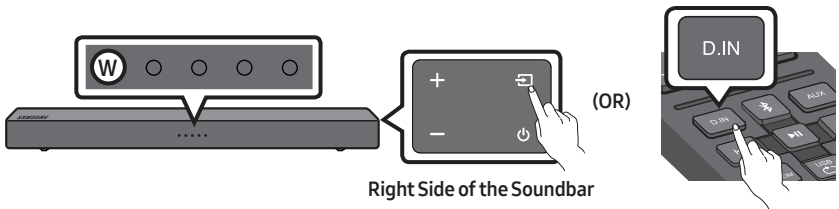

Connecting using an Analogue Audio (AUX) Cable

Step 1. Connect using an Analogue Audio (AUX) Cable

BD / DVD player / Set-top box /
Game console

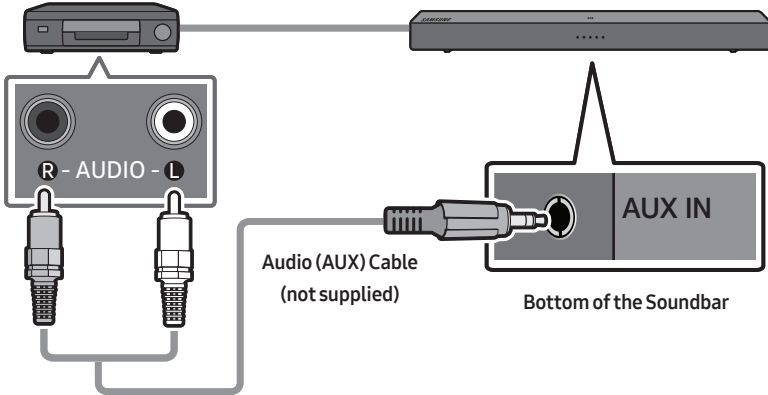

Step 2. Change the Soundbar's mode to AUX

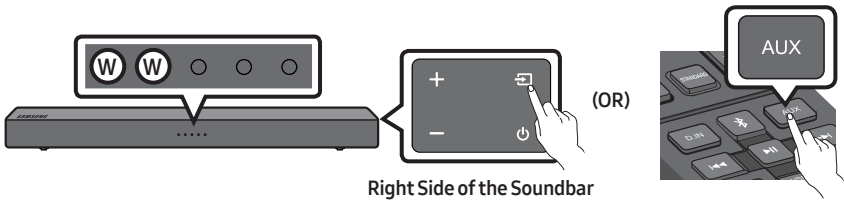

07 CONNECTING A USB STORAGE DEVICE

Step 1. Connect a USB Drive

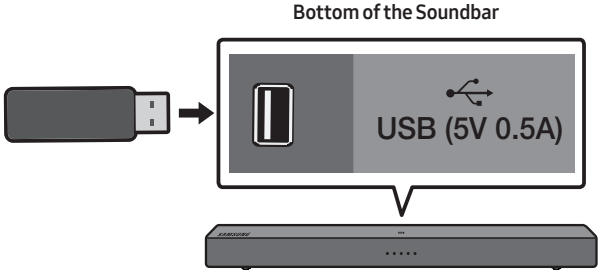

NOTE

- The Soundbar automatically turns off (Auto Power Off) if you do not connect a USB device to the Soundbar within 18 minutes.



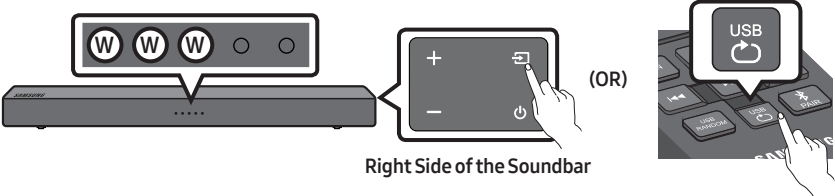



Step 2. Change the Soundbar's mode to USB



Setting Repeat Play Options



Repeat play

When the Soundbar is in “USB” mode, each time you press the  button the “USB” mode changes how it plays tracks in the following order: “Repeat - Off” > “Repeat - 1 song” > “Repeat - All songs”. See the table below for details.

Mode	Remote control Button	LED indicator
Repeat - Off		
Repeat - 1 song		
Repeat - All songs		

Repeat play at Random

When the Soundbar is in “USB” mode, once you press the  button, the “USB” mode changes how it plays tracks to “Repeat - Random”. See the table below for details.

Mode	Remote control Button	LED indicator
Repeat - Random		

File Format Type Compatibility list

Extension	Codec	Sampling Rate	Bitrate
*.mp3	MPEG 1 Layer2	16kHz ~ 48kHz	80kbps~320kbps
	MPEG 1 Layer3	16kHz ~ 48kHz	80kbps~320kbps
	MPEG 2 Layer3	16kHz ~ 48kHz	80kbps~320kbps
	MPEG 2.5 Layer3	16kHz ~ 48kHz	80kbps~320kbps
*.wma	Wave_Format_MSAudio1	16kHz ~ 48kHz	56kbps~128kbps
	Wave_Format_MSAudio2	16kHz ~ 48kHz	56kbps~128kbps
*.aac	AAC	16kHz ~ 96kHz	48kbps~320kbps
	AAC-LC	16kHz ~ 96kHz	128kbps~192kbps 5.1ch 320kbps
	HE-AAC	24kHz ~ 96kHz	48kbps~64kbps 5.1ch 160kbps
*.wav	-	16kHz ~ 48kHz	up to 3000kbps
*.flac	FLAC 1.1.0,FLAC 1.2.1	16kHz ~ 96kHz	up to 3000kbps

- If there are too many folders and files stored on the USB device, it may take the Soundbar some time to access and play files.

08 SYSTEM INITIALISE

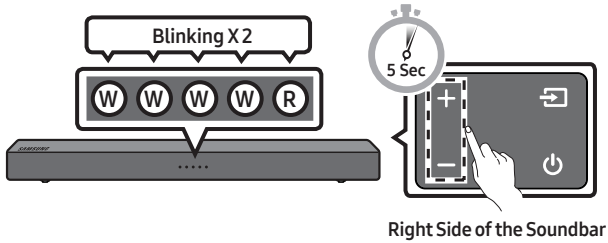

Right Side of the Soundbar

With the Soundbar on, press the **+ - (Volume)** buttons on the body at the same time for at least 5 seconds.

CAUTION

- All the settings of the Soundbar are initialised. Be sure to perform this only when initialization is required.

09 INSTALLING THE WALL MOUNT (OPTIONAL)

Installation Precautions

- Install on a vertical wall only.
- Do not install in a place with high temperature or humidity.
- Verify whether the wall is strong enough to support the product's weight. If not, reinforce the wall or choose another installation point.
- Purchase and use the fixing screws or anchors appropriate for the kind of wall you have (plaster board, iron board, wood, etc.).
If possible, fix the support screws into wall studs.
- Purchase wall mounting screws according to the type and thickness of the wall you want to mount the Soundbar on.
 - Diameter: M4
 - Length: 40 mm or longer recommended.
- Connect cables from the unit to external devices before you install the Soundbar on the wall.
- Make sure the unit is turned off and unplugged before you install it. Otherwise, it may cause an electric shock.

Wall mount Components

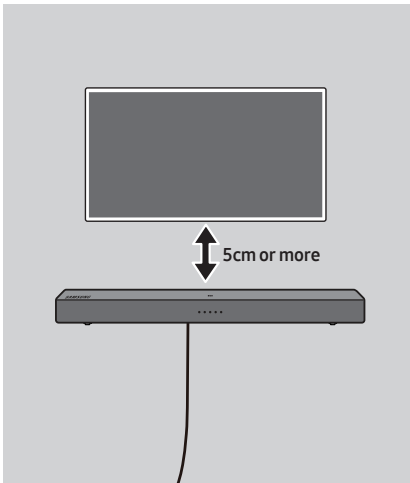

For Installation on Concrete Walls (not supplied)

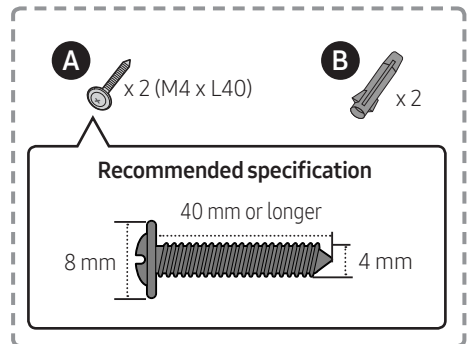

NOTE

- Installations on other types of walls will require different kinds of screws.

1.

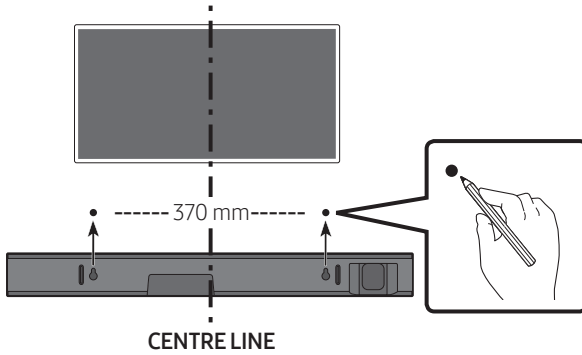

NOTES

- If your TV is installed on the wall, install the Soundbar 5cm or more below your TV.
- Use a pencil to mark the holes' positions.

2.

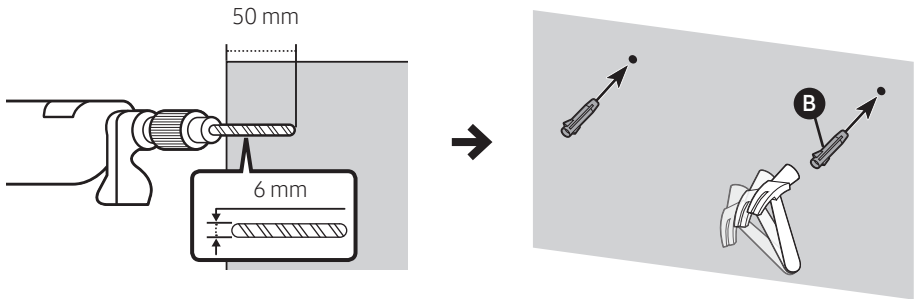

IMPORTANT NOTE

- The installation method shown here is for CONCRETE walls. Installation methods will vary depending on the wall type. For installation on dry wall, we strongly recommend you drill screw support holes into the underlying wood studs.

3.

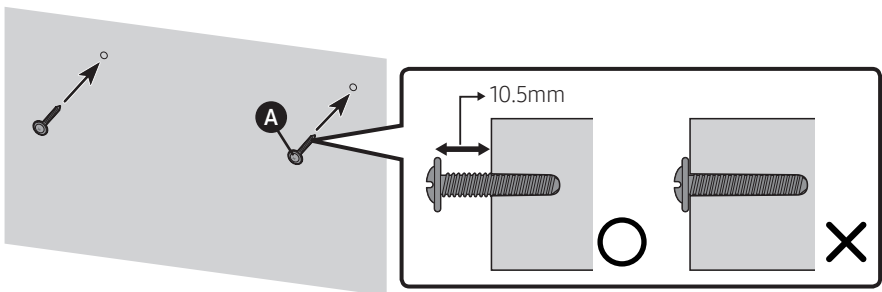

4.

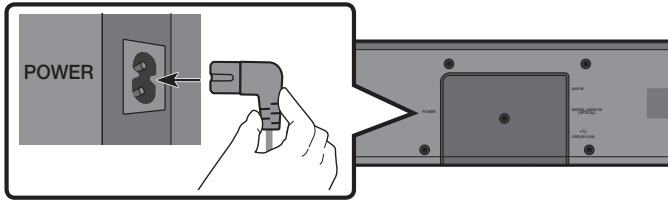

5.

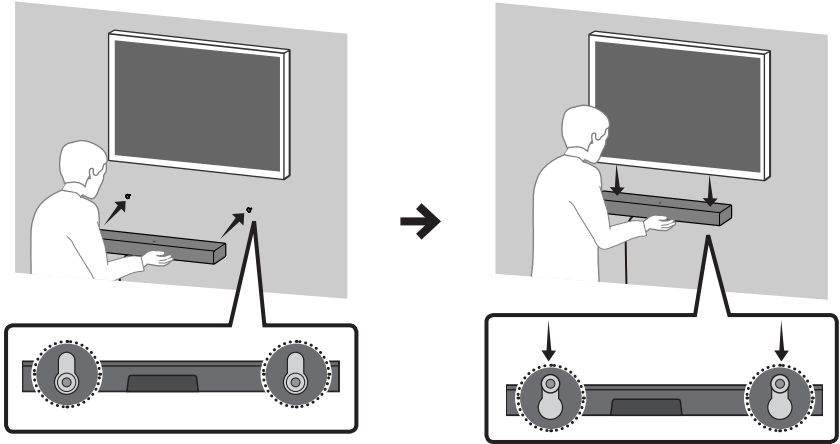

NOTE

- Supports for wall installation are built into the back of the Soundbar.

CAUTION

- Press the Soundbar down with sufficient force to fix it to the wall. If the Soundbar is not firmly fixed to the wall, it could be accidentally detached, resulting in personal injury.
- Do not bump into or strike the Soundbar (especially from the bottom). The impact could detach the Soundbar from the wall, resulting in personal injury.

10 SOFTWARE UPDATE

Samsung may offer updates for the Soundbar's system firmware in the future.

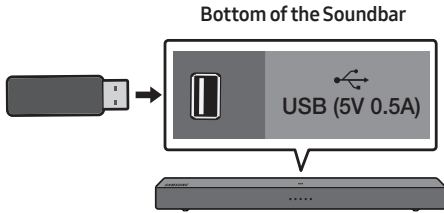

If an update is offered, you can update the firmware by connecting a USB device with the firmware update stored on it to the USB port on your Soundbar. For more information about how to download update files, go to the Samsung website at (www.samsung.com → Support). Then, enter or select the model number of your Soundbar, select the Software & Apps option, and then Downloads. Note that the option names can vary.

Update Procedure

Important: The updating function erases all user settings. We recommend you write down your settings so that you can easily reset them after the update.

1. Connect a USB thumb drive to the USB port on your computer.
Important: Make sure there are no music files on the USB thumb drive. This may cause the firmware update to fail.
2. Go to the Samsung website at (samsung.com) → select Enter Model Number and enter the model of your Soundbar. Select manuals and downloads and download the latest software file.
3. Save the downloaded software to a USB stick and select "Extract Here" to unzip the folder.
4. Turn off the Soundbar and connect the USB stick containing the software update to the USB port.
5. Disconnect the power cord, reconnect it, and then turn on the Soundbar.
6. Turn on the Soundbar and select mode to USB. Within 3 minutes, 4 white LEDs on and update begins.
7. When the update finishes, the Soundbar turns off. Press the  button on the remote control for 5 seconds. All LEDs blink 2 times and then the Soundbar turns off. The update is complete.
 - If the firmware fails to update, you can update the firmware again.
8. Restore your settings on the Soundbar.

When update fails

1. Turn off the Soundbar, disconnect and then reconnect the USB storage device that contains the update files to the Soundbar's USB port.
2. Disconnect the Soundbar's power cord, reconnect it, and then turn on the Soundbar.

NOTES

- The firmware update may not work properly if audio files supported by the Soundbar are stored in the USB storage device.
- Do not disconnect the power or remove the USB device while updates are being applied. The main unit will turn off automatically after completing the firmware update.
- After the update is completed, the user setup in the Soundbar is initialised so you can reset your settings. We recommend you write down your settings so that you can easily reset them after the update. If the software update fails, check if the USB stick is defective.
- Mac OS users should use MS-DOS (FAT) as the USB format.
- Updating via USB may not be available, depending on the USB storage device manufacturer.

11 TROUBLESHOOTING

Before seeking assistance, check the following.

The unit will not turn on.

Is the power cord firmly plugged into the wall outlet?

- Unplug and reconnect the power cord to the wall outlet to make sure the connection is secure.

A function does not work when the button is pressed.

Is there static electricity in the air?

- Disconnect the power plug and connect it again.

Sound dropouts occur in Bluetooth mode.

- See the Bluetooth connection sections on pages 16 ~ 18.
- In Bluetooth connection mode, the Bluetooth connection will be lost if the distance between the Soundbar and the Bluetooth device exceeds 10 m.

Sound is not produced.

Is the Mute function on?

- Press the **VOL** button to cancel the function.

Is the volume set to minimum?

- Adjust the Volume.

The remote control does not work.

Is the battery drained?

- Replace with new batteries.

Is the distance between the remote control and Soundbar main unit too far?

- Move the remote control closer to the Soundbar main unit.

12 LICENCE



Manufactured under license from Dolby Laboratories. Dolby, Dolby Audio, and the double-D symbol are trademarks of Dolby Laboratories.



For DTS patents, see <http://patents.dts.com>.
Manufactured under license from DTS Licensing Limited. DTS, the Symbol, DTS in combination with the Symbol, and DTS 2.0 Channel are registered trademarks or trademarks of DTS, Inc. in the United States and/or other countries. © DTS, Inc. All Rights Reserved.



The Bluetooth® word mark and logos are registered trademarks owned by the Bluetooth SIG, Inc. and any use of such marks by Samsung Electronics Co., Ltd. is under license. Other trademarks and trade names are those of their respective owners.

13 OPEN SOURCE LICENCE NOTICE

To send inquiries and requests regarding open sources, contact Samsung via Email (oss.request@samsung.com).



14 IMPORTANT NOTES ABOUT SERVICE

- Figures and illustrations in this User Manual are provided for reference only and may differ from actual product appearance.
- An administration fee may be charged if either
 - (a) an engineer is called out at your request and there is no defect with the product (i.e. where the user manual has not been read).
 - (b) you bring the unit to a repair centre and there is no defect with the product (i.e. where the user manual has not been read).
- You will be informed of the administration fee amount before a technician visits.

15 SPECIFICATIONS AND GUIDE

Specifications

Model Name	HW-T400
USB	5V/0.5A
Weight	2.0 kg
Dimensions (W x H x D)	641.0 x 65.0 x 107.0 mm
Operating Temperature Range	+5°C to +35°C
Operating Humidity Range	10 % ~ 75 %
Supported play formats (DTS 2.0 sound is played in DTS format.)	LPCM 2ch, Dolby Audio™ (supporting Dolby® Digital), DTS
WIRELESS DEVICE OUTPUT POWER BT max transmitter power	100mW at 2.4GHz – 2.4835GHz

Overall Standby Power Consumption (W)	1.0W
Disabling Bluetooth	Press and hold the  button for more than 5 seconds to turn off Bluetooth Power function.
Enabling Bluetooth	Press and hold the  button for more than 5 seconds to turn on Bluetooth Power function.

NOTES

- Samsung Electronics Co., Ltd reserves the right to change the specifications without notice.
- Weight and dimensions are approximate.

- Hereby, Samsung, declares that this equipment is in compliance with Directive 2014/53/EU.

The full text of the EU declaration of conformity is available at the following internet address: <http://www.samsung.com> go to Support > Search Product Support and enter the model name.

This equipment may be operated in all EU countries.





[Correct disposal of batteries in this product]

(Applicable in countries with separate collection systems)

This marking on the battery, manual or packaging indicates that the batteries in this product should not be disposed of with other household waste at the end of their working life. Where marked, the chemical symbols Hg, Cd or Pb indicate that the battery contains mercury, cadmium or lead above the reference levels in EC Directive 2006/66.

If batteries are not properly disposed of, these substances can cause harm to human health or the environment.

To protect natural resources and to promote material reuse, please separate batteries from other types of waste and recycle them through your local, free battery return system.



Correct Disposal of This Product (Waste Electrical & Electronic Equipment)

(Applicable in countries with separate collection systems)

This marking on the product, accessories or literature indicates that the product and its electronic accessories (e.g. charger, headset, USB cable) should not be disposed of with other household waste at the end of their working life. To prevent possible harm to the environment or human health from uncontrolled waste disposal, please separate these items from other types of waste and recycle them responsibly to promote the sustainable reuse of material resources.

Household users should contact either the retailer where they purchased this product, or their local government office, for details of where and how they can take these items for environmentally safe recycling.

Business users should contact their supplier and check the terms and conditions of the purchase contract. This product and its electronic accessories should not be mixed with other commercial wastes for disposal.

For information on Samsung's environmental commitments and product specific regulatory obligations e.g. REACH, WEEE, Batteries, visit:
http://www.samsung.com/uk/aboutsamsung/samsungelectronics/corporatecitizenship/data_corner.html



UNITED KINGDOM



EIRE

This Samsung product is warranted for the period of twelve (12) months from the original date of purchase, against defective materials and workmanship. In the event that warranty service is required, you should return the product to the retailer from whom it was purchased. However, Samsung Authorised Dealers and Authorised Service Centres in other EC Countries will comply with the warranty on the terms issued to purchasers in the country concerned. In case of difficulty, details of our Authorised Service Centres are available from:

Samsung Electronics U.K. Ltd
Samsung Customer Support Centre
Selectapost 38, Sheffield, S97 3FJ
United Kingdom

United Kingdom
Tel : 0333 000 0333
www.samsung.com/uk/support

EIRE
Tel : 0818 717100
www.samsung.com/ie/support

■ WARRANTY CONDITIONS

1. The warranty is only valid if, when warranty service is required, the warranty card is fully and properly completed and is presented with the original invoice or sales slip or confirmation, and the serial number on the product has not been defaced.
2. Samsung's obligations are limited to the repair or, at its discretion, replacement of the product or the defective part.
3. Warranty repairs must be carried out by Authorised Samsung Dealers or Authorised Service Centres. No re-imburement will be made for repairs carried out by non Samsung Dealers and, any such repair work and damage to the products caused by such repair work will not be covered by this warranty.
4. This product is not considered to be defective in materials nor workmanship by reason that it requires adaptation in order to conform to national or local technical or safety standards in force in any Country other than the one for which the product was originally designed and manufactured. This warranty will not cover, and no re-imburement will be made for such adaptation nor any damage which may result.
5. This warranty covers none of the following:
 - a) Periodic check ups, maintenance and repair or replacement of parts due to normal wear and tear.
 - b) Cost relating to transport, removal or installation of the product.
 - c) Misuse, including the failure to use this product for its normal purposes or incorrect installation.
 - d) Damage caused by Lightning, Water, Fire, Acts of God, War, Public Disturbances, incorrect mains voltage, improper ventilation or any other cause beyond the control of Samsung.
6. This warranty is valid for any person who legally acquired possession of the product during the warranty period.
7. The consumers statutory rights in any applicable national legislation whether against the retailer arising from the purchase contract or otherwise are not affected by this warranty. Unless there is national legislation to the contrary, the rights under this warranty are the consumers sole rights and Samsung, its subsidiaries and distributors shall not be liable for indirect or consequential loss or any damage to records, compact discs, videos or audio taper or any other related equipment or material.

SAMSUNG ELECTRONICS (U.K.) LTD.

SAMSUNG

© 2020 Samsung Electronics Co., Ltd. All rights reserved.

Contact SAMSUNG WORLD WIDE

If you have any questions or comments relating to Samsung products, please contact the SAMSUNG customer care Centre.

Area	Contact Centre ☎	Web Site	Area	Contact Centre ☎	Web Site
■ Europe					
UK	0333 000 0333	www.samsung.com/uk/support	CZECH	800 - SAMSUNG (800-726786)	www.samsung.com/cz/support
IRELAND (EIRE)	0818 717100	www.samsung.com/ie/support	SLOVAKIA	0800 - SAMSUNG (0800-726 786)	www.samsung.com/sk/support
GERMANY	06196 77 555 77	www.samsung.com/de/support	CROATIA	072 726 786	www.samsung.com/hr/support
FRANCE	01 48 63 00 00	www.samsung.com/fr/support	BOSNIA	055 233 999	www.samsung.com/support
ITALIA	800-SAMSUNG (800.7267864)	www.samsung.com/it/support	NORTH MACEDONIA	023 207 777	www.samsung.com/mk/support
SPAIN	91 175 00 15	www.samsung.com/es/support	MONTENEGRO	020 405 888	www.samsung.com/support
PORTUGAL	808 207 267	www.samsung.com/pt/support	SLOVENIA	080 697 267 (brezplačna številka)	www.samsung.com/si/support
LUXEMBURG	261 03 710	www.samsung.com/be_fr/support	SERBIA	011 321 6899	www.samsung.com/rs/support
NETHERLANDS	088 90 90 100	www.samsung.com/nl/support	KOSOVO	0800 10 10 1	www.samsung.com/support
BELGIUM	02-201-24-18	www.samsung.com/be/support (Dutch) www.samsung.com/be_fr/support (French)	ALBANIA	045 620 202	www.samsung.com/al/support
NORWAY	21629099	www.samsung.com/no/support	BULGARIA	*3000 Цена на един градски разговор 0800 111 31 Безплатен за всички оператори	www.samsung.com/bg/support
DENMARK	707 019 70	www.samsung.com/dk/support	ROMANIA	*8000 (apel în rețea) 08008-726-78-64 (08008-SAMSUNG) Apel GRATUIT Atenție: Dacă efectuați apelul din rețeaua Digi (RCS/RDS), vă rugăm să ne contactați formând numărul Telverde fără ultimele două cifre, astfel: 0800872678.	www.samsung.com/ro/support
FINLAND	030-6227 515	www.samsung.com/fi/support	CYPRUS	8009 4000 only from landline, toll free	www.samsung.com/gr/support
SWEDEN	0771 726 786	www.samsung.com/se/support	GREECE	80111-SAMSUNG (80111 726 7864) only from land line (+30) 210 6897691 from mobile and land line	
POLAND	801-172-678* lub +48 22 607-93-33* Specjalistyczna infolinia do obsługi zapytań dotyczących telefonów komórkowych: 801-672-678* * (opłata według taryfy operatora)	http://www.samsung.com/pl/support/	LITHUANIA	8-800-77777	www.samsung.com/lt/support
HUNGARY	0680SAMSUNG (0680-726-7864)	www.samsung.com/hu/support	LATVIA	8000-7267	www.samsung.com/lv/support
AUSTRIA	0800 72 67 864 (0800-SAMSUNG)	www.samsung.com/at/support	ESTONIA	800-7267	www.samsung.com/ee/support
SWITZERLAND	0800 726 786	www.samsung.com/ch/support (German) www.samsung.com/ch_fr/support (French)			