

BUSH

Instruction Manual

PR-206



Table of content

Help and guidance	1
Safety information	2
Function	2
Important safeguards	2-3
Location of Control	4
Before first use	4
Main operation	4
Battery operation	4
Battery safety	4
Radio Operation	5
Using Headphones (not included)	5
Cleaning and Care	5
Troubleshooting Guide	5
Specification	5
Product support	6
Disposal	6
Guarantee	7
Important Data Protection information	7

You'll soon be enjoying your new Analogues Radio.

It all begins here, with your instructions. Don't worry, there's nothing too technical coming up. Just simple, step-by-step guidance to get you up and running quickly. Sound good? Then let's get started.

Help and Guidance

We're here to help you get the most from your radio. Should you require any guidance, a simple solution can often be found online at:

www.argos-support.co.uk

If you still require further assistance, call one of our experts on 0345 604 0105.



Safety Information

Important – Please read these instructions fully before installing or operating

FUNCTIONS

- ▶ FM: 88 – 108 MHz / AM: 530 – 1600 KHz Radio
- ▶ Headphone Jack
- ▶ AC/DC operation

IMPORTANT SAFEGUARDS

Please read this instruction manual thoroughly before using this appliance! Follow all the safety instructions to avoid damage caused by improper use.

- ▶ Keep the instruction manual for future reference. Should this appliance be given to a third party, then this instruction manual must also be handed over.
- ▶ Use this appliance solely for its intended purpose.
- ▶ This appliance is intended for household use only.
- ▶ Only use this appliance indoors.
- ▶ **Danger of electroshock!** Do not immerse the appliance, power cord or power plug in water or in other liquids.
- ▶ Do not place the appliance in the direct vicinity of liquids - e.g. bathtubs and sinks, in a damp basement or close to a swimming pool.
- ▶ Do not start up the appliance with damp hands or if you are standing on a wet floor. Never grasp the power plug with damp or wet hands.
- ▶ The manufacturer assumes no liability for possible damages that may have been caused by incorrect usage or mishandling of the appliance.
- ▶ This appliance is not intended for use by young children or infirm persons unless they have been adequately supervised by a responsible person to ensure that they can use the appliance safely.
- ▶ Young children should be supervised to ensure that they don't play with the appliance.
- ▶ Keep the appliance away from all hot surfaces and naked flames.
- ▶ Do not place any objects on the appliance. Don't put objects with naked flames (such as candles) on or next to the appliance. Never put items containing liquid (such as vases) on or next to the appliance.
- ▶ Do not expose the appliance to direct sunlight.
- ▶ Do not use the appliance if it is damaged. To avoid hazards, defective components must only be replaced by the manufacturer, his customer service or similar qualified persons.
- ▶ Do not dismantle and repair the appliance by yourself.
- ▶ Do not insert any foreign objects into the housing.
- ▶ Do not cover the appliance while in use.
- ▶ This appliance should be only operated with the type of power source, or batteries indicated on the marking label. Marketing label is located at rear enclosure of the apparatus.
- ▶ Always turn the power off before plugging the appliance into the power outlet or unplugging it.
- ▶ Prevent damage to the power cord by not squeezing, bending or rubbing it on sharp edges. Keep the cord away from hot surfaces and open flames.
- ▶ Always pull the plug, not the power cord when disconnecting the appliance from a power outlet.
- ▶ Plug the appliance into an easily accessible socket, so that you can disconnect it quickly from the mains, in the event of an emergency. Unplug the appliance from the power socket to switch it off completely. Use the mains plug as a disconnecting appliance.
- ▶ If the appliance malfunctions due to electrostatic discharge or short-term overvoltage, disconnect it from the power supply and connect it once again.
- ▶ Ensure minimum distances of 5 cm around the apparatus for sufficient ventilation. Do not place the product in closed bookcases or racks without proper ventilation. The ventilation should not be impeded by covering the ventilation openings with items, such as newspapers, table-cloths, curtains, etc.
- ▶ Do not use or store the equipment in humid or dusty area. Attention should be drawn to the use of apparatus in tropical and/ or moderate climates.
- ▶ To prevent possible hearing damage, do not listen at high volume levels for long periods.



BATTERY SAFETY

- ▶ Only use Alkaline or rechargeable batteries.
- ▶ If the batteries leak, remove them with a cloth and dispose of them accordingly. Ensure that leaking battery acid does not come into contact with skin and eyes. If you do get battery acid in your eyes, flush them thoroughly with lots of water and consult a physician immediately! If battery acid comes into contact with your skin, wash the affected area with lots of water and soap.
- ▶ **Danger of explosion!** Batteries must not be charged or reactivated by other means, taken apart, thrown in the fire or short-circuited.
- ▶ Do not expose batteries to extreme temperatures such as from direct sunlight or fire. Do not place the appliance on a heater. Leaking battery acid can cause damage.
- ▶ **Caution!** There is a danger of explosion if the batteries are inserted incorrectly. Use only the same battery types with the corresponding technical data to replace them.
- ▶ Do not use old and new batteries or batteries of a different type or that are from different manufacturers together.
- ▶ Always insert batteries in accordance with the correct polarity (+ and -) as illustrated in the battery compartment.
- ▶ Batteries are life-threatening if swallowed. Store all batteries out of the reach of small children and domestic animals. Seek medical help immediately if batteries are swallowed.
- ▶ Do not allow children to change batteries without adult supervision.
- ▶ If the battery compartment door does not secure closely, stop using the appliance and keep it away from the children.
- ▶ If you think batteries might have been swallowed or placed inside any part of the body, seek immediate medical attention.
- ▶ If the device is not to be used for an extended period of time, then the batteries should be removed, as the device could become damaged should they leak.
- ▶ If the device functions weaken, replace all batteries.
- ▶ Remove the batteries prior to disposing of the device.
- ▶ **Batteries do not belong in household waste!** Expired batteries must be disposed of in an environmentally friendly way and according to the applicable legal regulations.

LOCATION OF CONTROL

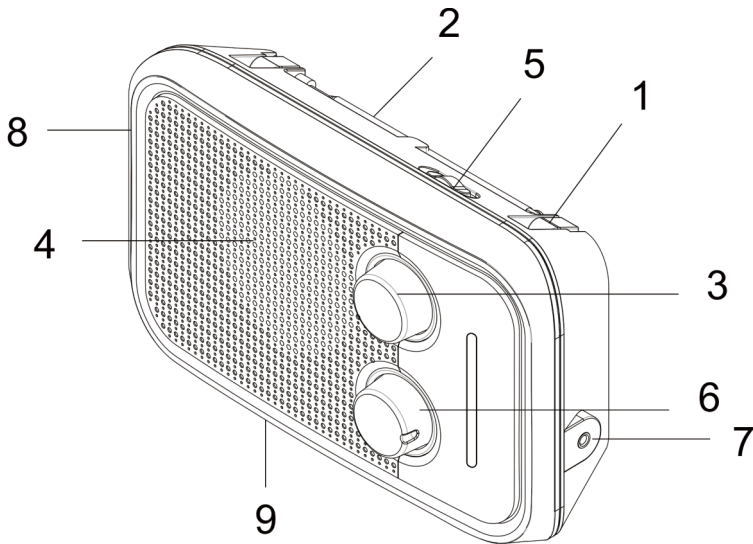

- | | |
|----------------------------|---------------------------------|
| 1. Handle | 6. Volume control - on/off knob |
| 2. FM antenna (telescopic) | 7. Headphone jack |
| 3. Tuning control knob | 8. AC socket |
| 4. Speaker | 9. Battery compartment |
| 5. Waveband selector | 10. AC Power cable (not shown) |

BEFORE FIRST USE

- ▶ Unpack the appliance and check if all parts are there and undamaged. Should this not be the case, return the product to Kmart for replacement.
- ▶ **Danger of suffocation!** Keep all packaging materials away from children.
- ▶ Dispose of the packaging materials properly. Inform yourself at the local authorities regarding collection points or garbage separation.
- ▶ Remove all protective foils and packaging material prior to use.

MAINS OPERATION

Fit the AC power cord into the AC socket (8) of the appliance and plug into the household socket.

BATTERY OPERATION

To use the appliance with batteries ensure that the AC power cord is NOT inserted into the back of the appliance and install the batteries into the battery compartment.

1. Disconnect the radio from power.
2. Remove the door of the battery compartment (9).
3. Insert 4 x Size "C" / UM-2 / R14 (not supplied) 1.5V heavy-duty alkaline batteries in accordance with the diagram in the battery compartment. Take care to observe the correct polarity (+/-).
4. Refit the battery compartment cover.

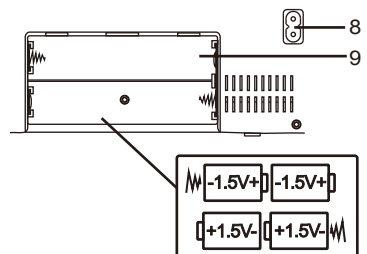

RADIO OPERATION

Listening to the Radio

1. Turn the **volume control** - on/off knob (6) upward to switch the radio on.
2. Set the **waveband selector** (5) to required waveband.
3. Turn the **tuning control knob** (3) to select the frequency and station of choice. The radio frequency scale will show the waveband selected.
4. To turn off the radio, turn the **volume control** - on/off knob (6) downward until a “click sound is heard.

Volume Control

1. Adjust the volume to the desired level by rotating the **volume control knob** (6).

Achieve Optimum Reception

1. The built-in AM and the external FM antennas are directional. If tuning into a FM station extend or move the antenna (2) for a better reception. If tuning into an AM station rotate the whole unit after tuning to obtain the best reception.

USING HEADPHONES (NOT INCLUDED)

1. A headphone jack has been provided so that the set can be used without disturbing others. Plug in the 3.5mm headphone at the point marked '🎧'. Turn the listening volume to the lowest setting before adjusting the volume up to your chosen level.
Excessive sound pressure from earphones and headphones can cause hearing loss. The speaker will not operate when headphones are fitted.

CLEANING AND CARE

Danger of electroshock! Do not immerse the appliance in water or in other liquids.

1. Wipe the housing with a dry, soft cloth.
2. Do not use petrol, alcohol or other abrasive cleaners to clean the device.

TROUBLESHOOTING GUIDE

Observation	Potential cause / solution
The unit does not work on AC	Does the socket that is being used have power?
The unit does not work on batteries	Has the AC lead been removed from the unit? Are the batteries exhausted? Have the batteries been inserted correctly?
No sound	Is the volume control set at MIN? Are headphones fitted in the phones jack?
Radio reception weak	AM signals - rotate the unit to improve reception. AM signals - extend or adjust the position of FM antenna.

SPECIFICATION

Rated voltage: AC 230-240V ~ 50Hz, 5W

Battery: 4 x 1.5V Battery size "C"/UM-2/R14 or equivalent (not included)

Frequency range: AM 530 – 1600 kHz

FM 88 – 108MHz

Output power (RMS): 0.5W

Operating conditions: Temperature: 5°C to 35°C

Humidity: 5% to 90%

Due to continuous product development, design and specifications are subject to change without notice.

Product Support

Help is always at hand

Help and assistance

If you require any technical guidance or find that your Analogue Radio is not operating as intended, a simple solution can often be found in the Troubleshooting section of these instructions or online at www.argos-support.co.uk.

If you still require further assistance, call one of our experts on 0345 604 0105.

Local call rates applies*

Lines open 8am-7pm Monday to Saturday and 10am-4pm Sunday.

*Calls to Argos enquiry lines may attract a charge and set up fee from residential lines depending on your call plan/tariff. Mobile and other providers costs may vary, see www.bt.com/pricing for details.

For Security and training purposes, telephone calls to and from customer service centres maybe recorded and monitored. Calls from Republic of Ireland will attract international call charges.

Disposal



You should now recycle your waste electrical goods and in doing so help the environment. This symbol means an electrical product should not be disposed of with normal household waste. Please ensure it is taken to a suitable facility for disposal when finished with.

Visit www.recycle-more.co.uk, click on "bank locator" and enter your postcode to find your nearest recycling site.

This product is intended for use within the UK. This equipment complies with the essential requirements for the Radio Equipment Directive 2014/53/EU.



Declaration of Conformance

Hereby, Argos Ltd, declares that this Band II LPD device is in compliance with the essential requirements and other relevant provisions of Directive 2014/53/EU. The complete declaration of conformity can be obtained by contacting <http://www.argos-support.co.uk/>



Call us now and activate your 12 month guarantee
Thank you for choosing Bush. Your new product is guaranteed against
and breakdowns for 12 months. Don't forget to register it with us today so we
can provide you with our best possible after-sales service and useful updates.
www.bushregistration.co.uk

FREEPHONE*
0800 597 8548

Lines are open 8am - 8pm, 365 days a year. *Calls may be recorded and monitored.
Your Bush Guarantee

Your Bush Guarantee

This product is guaranteed for twelve months from the date of original purchase. Any defect that arises due to faulty materials or workmanship will be repaired free of charge (or if applicable the product will be replaced or the purchase price refunded) where possible during this period by the dealer from who your purchased the unit.

The guarantee is subject to the following provisions:

- The guarantee does not cover accidental damage, misuse, cabinet parts, knobs or consumable items.
- The product must be correctly installed and operated in accordance with the instructions contained in the manual.
- It must be used solely for domestic purposes. The guarantee will be rendered invalid if the product is re-sold or has been damaged by inexperienced repair.
- Specifications are subject to change without notice.
- Bush disclaim any liability for loss or damage arising from the breakdown of the product.
- This guarantee is in addition to and does not diminish your statutory or legal rights.

Important Data Protection Information

If you provide us with information about another person, you confirm that they have appointed you to act for them, to consent to the processing of their personal data including sensitive personal data and that you have informed them of our identity and the purposes (as set out in the Important Data Privacy notice displayed overleaf) for which their personal data will be processed.

You are entitled to ask for a copy of the information we hold about you (for which we may charge a small fee) and to have any inaccuracies in your information corrected.

For quality control and training purposes, we may monitor or record your communications with us.

If your personal details change, if you change your mind about any of your marketing preferences or if you have any queries about how we use your information, please let us know by contacting our Data Protection Officer, Domestic & General, Leicester House 17 Leicester Street, Bedworth, Warwickshire, CV12 8JP.

Guarantor: Argos Limited - 489 - 499 Avebury Blvd. - Milton Keynes - MK9 2NW