



**SPEAR &
JACKSON**

ORIGINAL INSTRUCTION MANUAL

36V

Cordless Lawnmower

SCR3637A



**Important - Please read these instructions
fully before starting assembly**

These instructions contain important information that will help you get the best from your mower, ensuring it is assembled correctly and safely. If you need help or have any missing parts call After Sales Support on 0345 605 2068

**AFTER SALES SUPPORT
0345 605 2068**

SPEAR & JACKSON SINCE 1760

For more than 250 years gardeners have enjoyed high quality performance and great results using Spear & Jackson tools.

Our garden power tools combine continuous innovation and the latest in manufacturing technologies with a proud heritage.

Each product is carefully designed with performance, comfort and durability firmly in mind, which has earned Spear & Jackson an enviable reputation as a maker of tools to trust.

3 YEARS GUARANTEE

As a testament to the quality of our products, we offer a 3 year manufacturers warranty and a comprehensive after sales service.

The warranty covers manufacturing faults, however in the event that the item has been deliberately damaged, used in a commercial environment or disassembled then the warranty will be null and void.

Please retain proof of purchase.

TECHNICAL SUPPORT

We want you to get the best out of your products. Our easy-to-read instruction manual guides you with best practice use and maintenance tips. Please call **0345 605 2068** for technical support, we can solve around 80% of questions directly over the phone.

We hope you enjoy your product and we look forward to any feedback, as this allows us to develop even better products for the future.

CONTENTS









Safety Information	4
Intended Purpose.....	4
Warning Symbols.....	4
Work Area Safety	6
Electrical Safety	6
Machine Use and Care	6
Personal Safety.....	7
Battery & Charger	7
Operating Safety	8
Maintenance and Storage Safety	12
Intended Use.....	12
In the Box	13
Parts.....	13
Assembly	14
Preparation	17
Operation	20
Maintenance	23
Technical Data	25
Troubleshooting	27
Warranty	29

SAFETY INFORMATION

INTENDED PURPOSE

The following warning symbols appear throughout this assembly manual and indicate the appropriate safety measures you should take when assembly and operating the mower.

WARNING SYMBOLS

-  Take extra care, beware of hazards.
-  Do not use the machine in the rain or leave it outdoors when it is raining.
-  Pay attention that bystanders are not injured by objects thrown out from the machine.
-  Keep bystanders a safe distance away from the machine.
-  Sharp blade. Beware of injury to toes or fingers.
-  Disconnect from the mains supply before any maintenance work.
-  Switch off and remove the isolator key before adjusting, cleaning or before leaving the product unattended for any period.
-  **WARNING!** Beware of electric shocks.



Wait until all moving parts have stopped completely before touching them. The blade may continue to rotate after the machine is switched off, a rotating blade can cause injury.



Read instruction handbook before operating this machine.



The charger is for indoor use only.

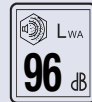

Guaranteed noise level.



Double insulation.



The product complies with the applicable European directives and an evaluation method of conformity for these directives was followed.



The product confirms to relevant UK regulatory requirements.

IPX1 Degree of Protection.

SAFETY INFORMATION



Rated Current of Protection Fuse.



Waste electrical products should not be disposed of with household waste. Please recycle where facilities exist. Check your Local Authority or retailer for recycling advice.



Batteries contain Lithium-ion. Do not dispose of batteries in with your general household waste, follow local legal requirements.



Do not dispose of batteries in rivers or immerse in water.



Do not dispose of battery packs in a fire. They will explode and cause injury.



Do not subject the battery to strong sunlight over long periods and do not leave it on a heater (max.45°C).



IMPORTANT!

When using equipment, the following safety precautions must be followed to avoid injuries and damage.

- Read all operating instructions carefully and comply with them. It is important to understand these instructions and to acquaint yourself with the machine, its correct usage and all safety requirements.
- Keep this manual in a safe place so that the information is available at all times.
- If you give the equipment to any other person, give them these operating instructions as well.

We accept no liability for damage or accidents which result from non-compliance with these instructions.

This appliance can be used by children aged from 8 years and above and person with reduce physical, sensory or mental capabilities or lack of experience and knowledge if they have been given supervision or instruction concerning use of the appliance in a safe way and understand the hazards involved.

Children shall not play with the appliance. Cleaning and user maintenance shall not be made by children without supervision.

SAFETY INFORMATION

WORK AREA SAFETY

- Inspect the area where the machine is to be used and remove all objects which can be thrown by the machine.
- Do not operate the machine in explosive atmospheres, such as in the presence of flammable liquids, gases or dust. Machines create sparks which may ignite the dust or fumes.
- Keep children and bystanders away while operating a machine. Distractions can cause you to lose control.

ELECTRICAL SAFETY

- The plug of charger must match the outlet. Never modify the plug in any way. Unmodified plugs and matching outlets will reduce the risk of electric shock.
- Do not expose the machine, battery and charger to rain or wet conditions. Water will increase the risk of electric shock.
- Do not abuse the cord of the charger. Never use the cord for carrying, pulling or

unplugging the charger. Keep the cord away from heat, oil, sharp edges or moving parts. Damaged or entangled cords increase the risk of electric shock.

- The voltage indicated on the charger rating plate must correspond to the voltage of the power source.
- Never touch the mains plug with wet hands.

MACHINE USE AND CARE

- Do not force the mower. Use the correct cutting height. If the mower is labouring due to the length of grass being cut raise the cutting height.
- Do not use a machine if the switch does not turn it on and off. Any machine that cannot be controlled with the switch is dangerous and must be repaired.
- Disconnect the plug from the power source or remove the battery pack from the machine before making any adjustments, changing accessories, or storing. Such preventive safety measures reduce the risk

SAFETY INFORMATION

of starting the machine accidentally.

- Store idle machines out of the reach of children and do not allow persons unfamiliar with the machine or these instructions to operate the machine. Machines can be dangerous in the hands of untrained users.
- Replace the blade when necessary.

PERSONAL SAFETY

- Stay alert, watch what you are doing and use common sense when operating the machine. Do not use the machine while you are tired or under the influence of drugs, alcohol or medication.
- Use personal protective equipment such as non-slip safety shoes.
- Prevent unintentional starting. Ensure the switch is in the off -position before connecting to power source and/or battery pack, picking up or carrying the machine.
- Do not carry the machine with your finger on the switch.

- Remove any adjusting key or wrench before turning the machine on. A wrench or a key left attached to a rotating part of the machine may result in personal injury.
- Do not overreach. Keep proper footing and balance at all times.
- Dress properly. Do not wear loose clothing or jewellery. Keep your hair, clothing and gloves away from moving parts. Loose clothes, jewellery or long hair can be caught in moving parts.

BATTERY AND CHARGER

- Recharge only with the charger specified by the manufacturer. A charger that is suitable for one type of battery pack may create a risk of fire when used with another battery pack. Incorrect use may result in electric shock, overheating or leakage of corrosive liquid from the battery.
- Use machines only with specifically designated battery packs. Use of any other battery packs may create a risk of injury and fire.

SAFETY INFORMATION

- When battery pack is not in use, keep it away from other metal objects, like paper clips, coins, keys, nails, screws or other small metal objects, that can make a connection from one terminal to another. Shorting the battery terminals together may cause burns or a fire.
- Under abusive conditions, such as an impact with a sharp object or exposure to temperatures exceeding 60C, liquid may be ejected from the battery; avoid contact. If contact accidentally occurs, flush with water. If liquid contacts eyes, additionally seek medical help. Liquid ejected from the battery may cause irritation or burns.

OPERATING SAFETY

TRAINING

- Read the instructions carefully. Be familiar with the controls and the proper use of the machine.
- Never allow people unfamiliar with these instructions or children to use the product. Local regulations can restrict the age of the operator.
- Never use the machine while people, especially children, or pets are nearby. Keep in mind that the operator or user is responsible for accidents or hazards occurring to other people or their property.

PREPARATION

- While operating the machine always wear substantial footwear and long trousers. Do not operate the machine when barefoot or wearing open sandals. Avoid wearing clothing that is loose fitting or that has hanging cords or ties.
- Thoroughly inspect the area where the machine is to be

SAFETY INFORMATION

used and remove all objects which can be thrown by the machine.

- Before using, always visually inspect to see that the blade, blade bolt and the blade assembly are not worn or damaged. Replace worn or damaged components in sets to preserve balance. Replace damaged or unreadable labels.

OPERATION

- Operate the machine only in daylight or in good artificial light. Do not expose the product to rain or wet conditions. Avoid using the product in bad weather conditions especially when there is a risk of lightning.
- Never operate the machine with defective guards or shields, or without safety devices, for example deflectors and/or grass collector, in place.
- Do not put hands or feet near rotating parts. Keep clear of the discharge opening at all times.
- Before use check the

controls and correct operation of the product.

- Before using the product or after any impact, check for signs of wear or damage and repair as necessary.
- Always disconnect the product from the power supply (i.e. remove the plug from the power supply or the remove the battery pack)
 - Whenever leaving the product unattended;
 - Before clearing a blockage;
 - Before checking, cleaning or working on the product
 - After striking a foreign object. (Inspect the machine for damage and make repairs before restarting and operating the machine.)
 - Whenever the product starts vibrating abnormally (check immediately).
- If the machine does start to vibrate abnormally (check immediately),
 - inspect for damage,
 - replace or repair any damaged parts,
 - check for and tighten any

SAFETY INFORMATION

loose parts.

- Always ensure that the air vents are kept clear of debris.
- For your safety do not use replacement parts or accessories not provided by or recommended by the manufacturer.
- Do not use the product if the cord is damaged or worn.
- Warning! The cutting blade may continue to move after the product is switched off.
- Always be sure of your footing on slopes.
- Walk, never run when using the mower.
- Mow across the face of slopes, never up and down.
- Exercise extreme caution when changing direction on slopes.
- Do not mow excessively steep slopes.
- Use extreme caution when reversing or pulling the machine towards you.
- Stop the blade(s) if the machine has to be tilted for transportation when crossing surfaces other

than grass, and when transporting the machine to and from the area to be used.

- Switch on the motor carefully according to instructions and with feet well away from the blade(s).
- Do not tilt the machine when switching on the motor, except if the machine has to be tilted for starting. In this case, do not tilt it more than absolutely necessary and lift only the part, which is away from the operator.
- Do not start the machine when standing in front of the discharge opening.
- Do not transport the machine while the cutting blade is running. Stop the machine, and remove the key/battery pack. Make sure that all moving parts have come to a complete stop.

EMERGENCY

- **WARNING!** Familiarise yourself with the use of this machine by means of this instruction manual. Memorise the safety directions and follow them

to the letter. This will help to prevent risks and hazards.

- Always be alert when using the machine, so that you can recognise and handle risks early. Fast intervention can prevent serious injury and damage to property.
- Switch off and disconnect from the power supply if there is any malfunction. If necessary have the machine checked by a qualified specialist and repaired before you operate it again.

RESIDUAL RISKS

- **WARNING!** Even if you are operating the machine in accordance with all safety requirements, potential risks of injury and damage remain. The following dangers can arise in connection with the structure and design of this machine:
- Health defects resulting from vibration emission if the machine is being used over long periods of time or not adequately managed and properly maintained.

- Injuries and damage to property due to broken application tools or sudden impact of hidden objects during use.
- **WARNING!** This machine produces an electromagnetic field during operation! This field may under some circumstances interfere with active or passive medical implants! To reduce the risk of serious or fatal injury, we recommend persons with medical implants to consult their doctor and medical implant manufacturer before operating this product!

SAFETY INFORMATION

MAINTENANCE AND STORAGE SAFETY

- Keep all nuts, bolts and screws tight to be sure the machine is in safe working condition.
- Check the grass collector frequently for wear or deterioration.
- Be careful during adjustment of the machine to prevent entrapment of the fingers between moving blades and fixed parts of the machine.
- Always allow the machine to cool down before storing.
- When servicing the blades be aware that, even though the power source is switched off, the blades can still be moved.
- Replace worn or damaged parts for safety. For your safety use only genuine replacement parts and accessories.

SERVICE

- This machine is manufactured in accordance with the relevant safety regulations. To avoid danger, equipment must only be repaired by qualified

technician.

- Use parts and accessories made for this machine by the manufacturer. Failure to do so can result in personal injury.

INTENDED USE

This lawnmower is designed for domestic use only:

- This cordless lawnmower is intended for mowing lawns in domestic and hobby gardens.
- This product is not to be used in wet weather conditions and may not be used to mow wet or unusually high grass.
- This product is intended for private domestic use only, not for any commercial trade use. It must not be used for any purposes other than those described. Any use of the machine that deviates from its intended use will invalidate the warranty.

IN THE BOX

PARTS

- | | | | |
|--------------------------|---------------------------------------|-------------------------------------|-----------------------------------|
| 1 Upper handle | 7 Upper Cover of Grass Collection Bag | 11 Cutting Height Adjustment Handle | 17 Cable Clip |
| 2 Switch Lever | 8 Deflector Guard | 12 Rear Wheel | 18 Grass Collector Full Indicator |
| 3 Wing knob | 9 Lower Cover of Grass Collection Bag | 13 Front Wheel | 19 Safety Button |
| 4 Cable Guide | 10 Carry Handle | 14 Deck | 20 Charger |
| 5 Grass Collector Handle | | 15 Battery Compartment Cover | 21 Battery (x2) |
| 6 Lower Handle | | 16 Isolator Key | 22 Mulching Plug |

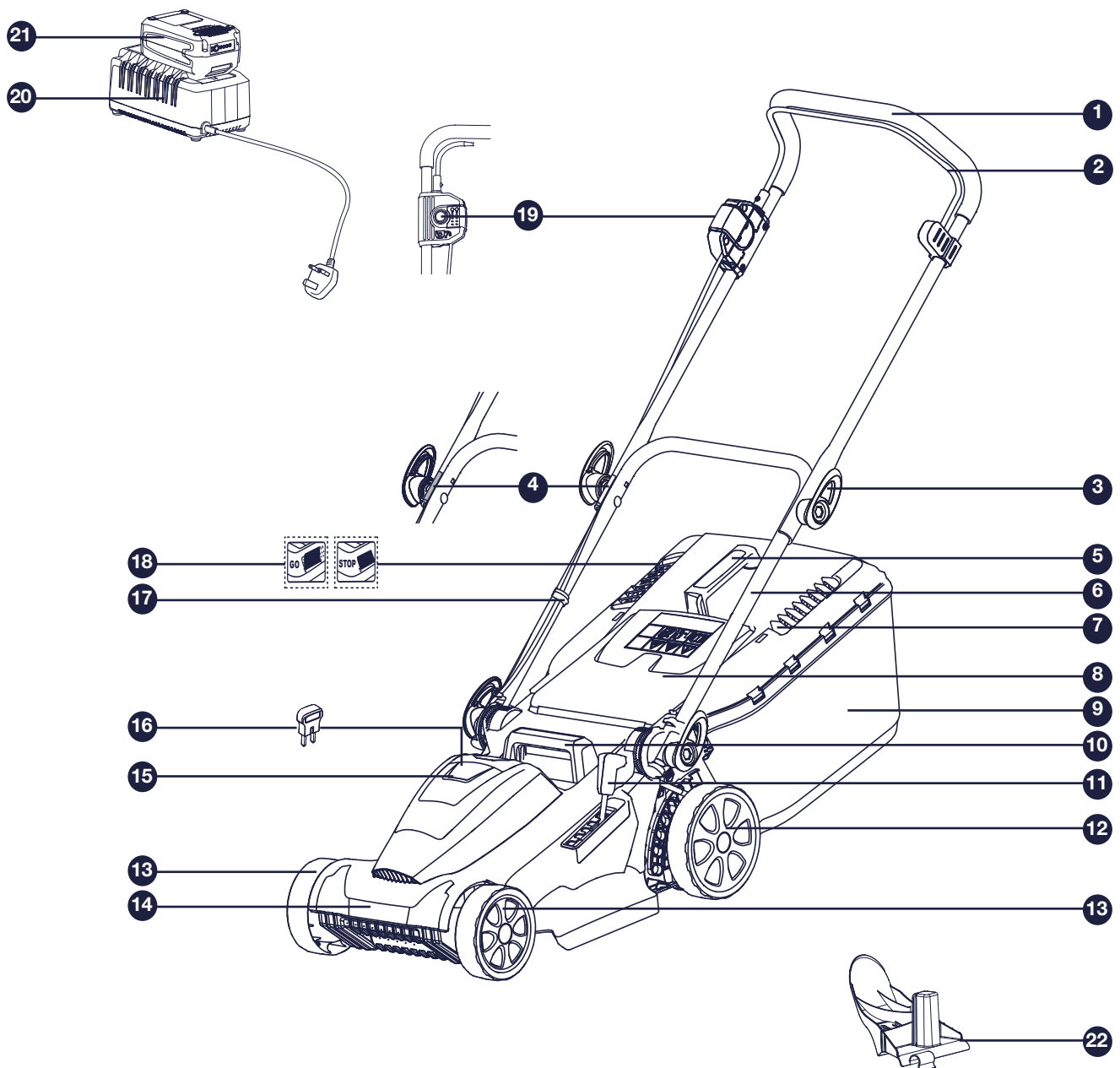

1 Unpacking

- i. Unpack all parts and lay them on a flat, stable surface.
- ii. Remove all packing materials and shipping devices if applicable.
- iii. Make sure the delivery contents are complete and free of any damage. If you find that parts are missing or show damage do not use the product but contact the aftersales helpline within 28 days of purchase. Using an incomplete or damaged product represents a hazard to people and property.
- iv. Ensure that you have all the accessories and tools needed for assembly and operation. This also includes suitable personal protective equipment.

2 Fix the lower handle

Adjust the lower handle to the desired position and turn the wing knob clockwise to secure in place.

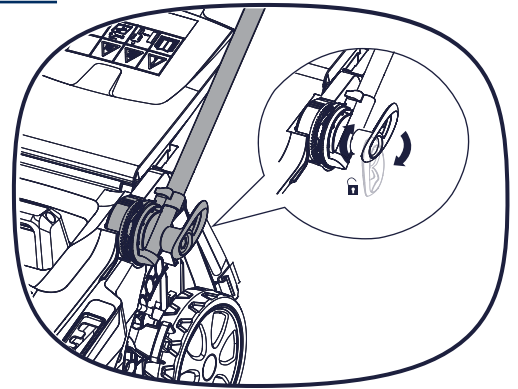

3 Fix the upper handle

Fit the upper handle and lower handle together with the wing knobs. Before fitting the wing knob, check and ensure the cable guide is attached on the upper handle. If not, attach the cable guide on the upper handle as shown. Ensure the hole on the cable guide is aligned with the hole on the upper handle. Insert the bolt through the inside of the lower handle, cable guide and upper handle assembly. Secure the wing knob to the bolt as shown.

There are two possible height positions. Choose the one most suitable to the operator's height.



WARNING! Make sure the cable guide is attached correctly on the upper handle to avoid the cable getting damaged when the upper handle is folded up and down.

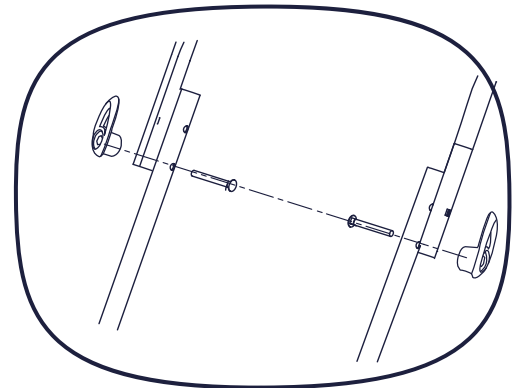
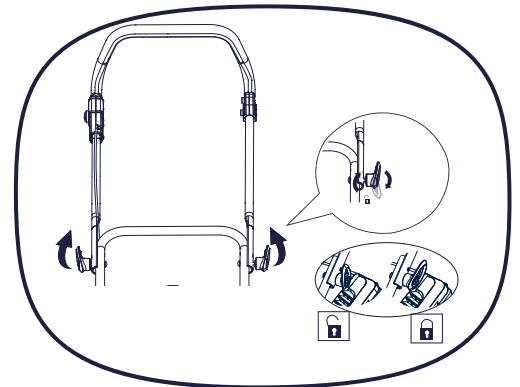
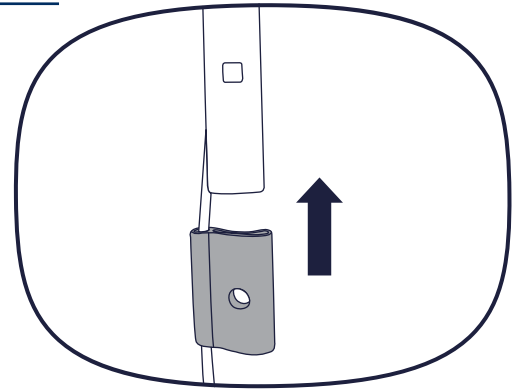

4 Fix the cable

Secure the cable against the handle frame with the supplied cable clip.

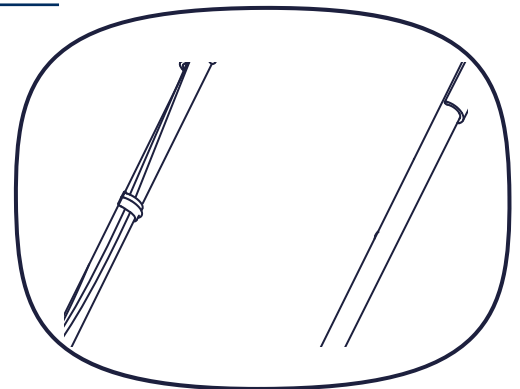

ASSEMBLY

5 Assemble the grass bag

i. Insert the handle in the upper cover of grass bag.

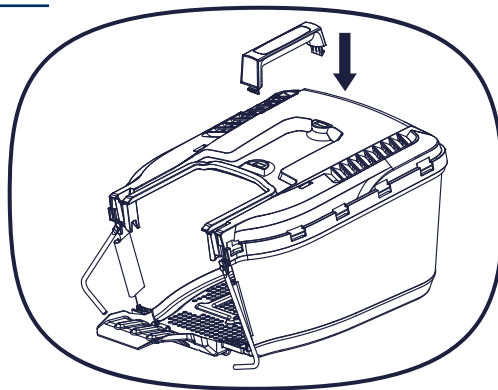

ii. Place the metal frame inside the grass collection bag, Make sure that these clips are fully secured to the metal frame.

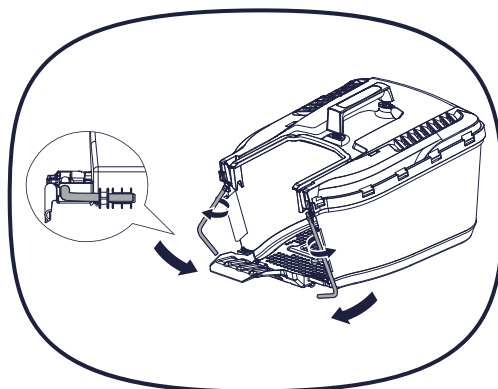

iii. To remove the mulching plug, grip the post and squeeze the lever, push down (1) to release the catch (2). Once the catch is released the mulching plug can be lifted out of the mower (3).

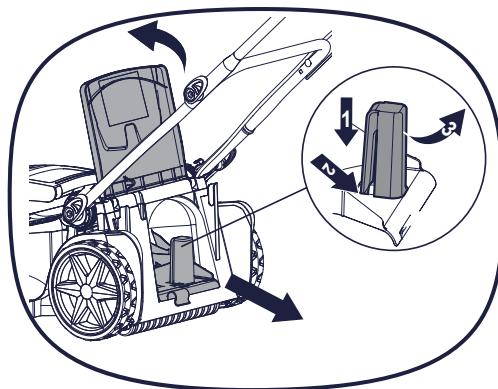

iv. Lift up the safety guard and attach grass collection bag onto the rear of the mower.

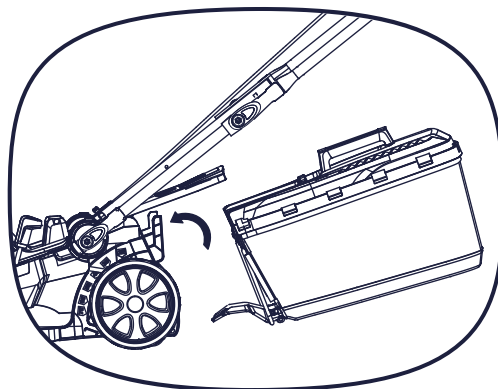

PREPARATION

1 Check battery capacity

Push the power indicator to show remaining battery capacity. The battery is equipped with a charge-level indicator panel which indicates charge condition. This charge-level indicator panel consists of 4 LEDs on the battery. Press and hold the charge indicator button on the battery to actuate the charge level indicator. The charge level indicator LEDs go out after releasing the button. The battery's charge level can be checked either when the battery is fitted on the machine or removed from the machine.

LED indicators on battery	Battery Capacity
Continuous lighting of 4 LEDs (inc 2 green)	Fully charged
Continuous lighting of 3 LEDs (inc 1 green)	≥ 50%
Continuous lighting of 2 LEDs (orange & red)	≥ 25%
Continuous lighting of 1 LED (red only)	≤ 25%. Recharge required.

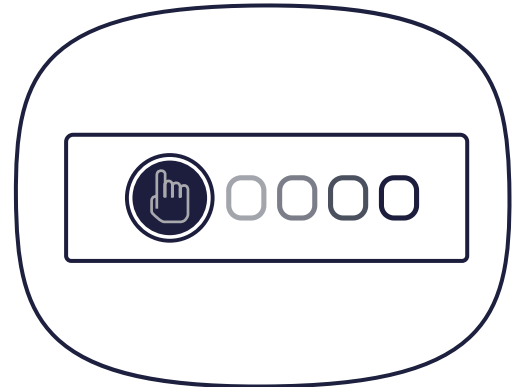
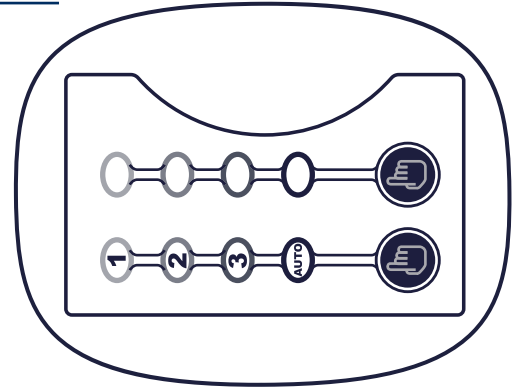

2 Battery Charging

i. Plug the charger into an appropriate AC power outlet.

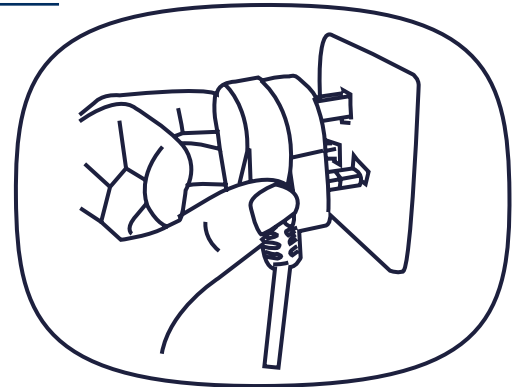



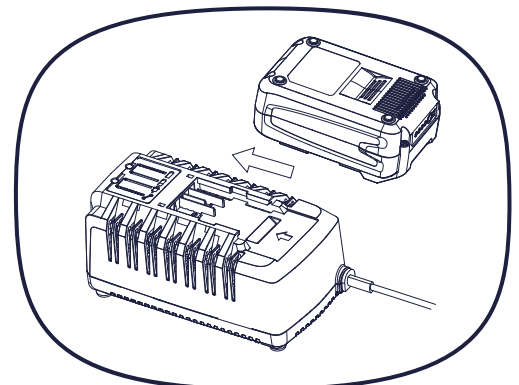



ii. Install the battery pack along the support rails of the charger.



PREPARATION

iii. The indicator lights on the charger show the charger status:

Symbol	Indicator lights	Status
		red, flashing
		red, continuous
		green, flashing at 1Hz
		green, flashing at 2Hz
		green, continuous

The intelligent charger measures the charge level of the battery pack and charges the battery accordingly with the required current and voltage, based on battery temperature and voltage, this ensures maximum battery life. Charge the battery fully before storage.

A flashing red LED light on the charger indicates that the battery temperature is below -5°C or the battery voltage is low, the battery will receive an extended charge cycle, approximately 30 minutes longer. This does not indicate a defect with the battery.

The red and green LED lights flicker alternately, indicating that an extended charge cycle is in progress. The purpose is to activate the low-voltage battery pack so that it can reach the voltage for normal charging.

A flashing at 2Hz green LED light on the charger indicates that the battery temperature is higher than 50°C .

As soon as the permitted temperature and the charging current ranges are reached, the battery charger will automatically switch to charging.

If the temperature range is correct and flashing red LED light continues, then remove and reinstall the battery pack. If the LED status repeats a second time, try to charge another identical battery. If the battery charges normally, dispose of the defective battery pack (see Recycling and Disposal section).

If the flashing red light continues after installing the second battery (ensure the battery temperature is normal), the charger may be defective. Replace with a new one.

After continuous or repeated charging cycles without interruption, the charger may warm up. This is normal and does not indicate a technical defect of the battery charger.

PREPARATION

3 Fit the battery

i. Lift the cover slide the battery along the rails and locks into position.

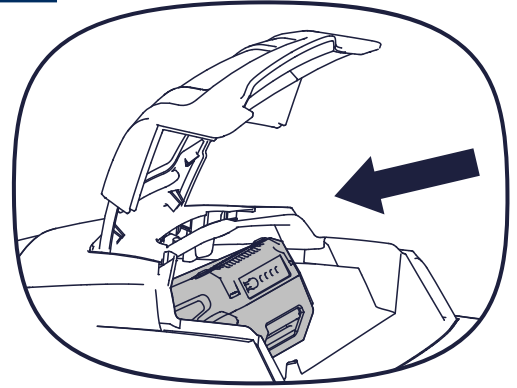

ii. Insert the isolator key.

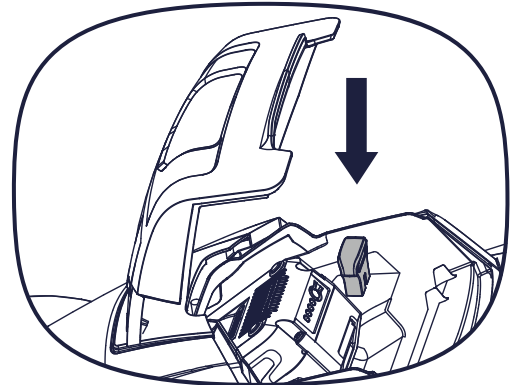

4 Mowing tips

- Verify that the lawn is free of stones, sticks, wires, and other objects that could damage the lawn mower.
- When cutting thick grass, reduce walking speed in order to allow for a more effective cut and a proper discharge of the clippings.
- Never cut off more than one-third of the total length of the grass for a healthy lawn. If it is roughly 6cm long, the grass should not be shorter than 4cm once mowed. If the grass is higher, you should gradually cut it down to the desired length so as not to damage the grass.
- Do not cut wet grass because it tends to stick to the underbody of the lawn mower, preventing the proper discharge of grass clippings.

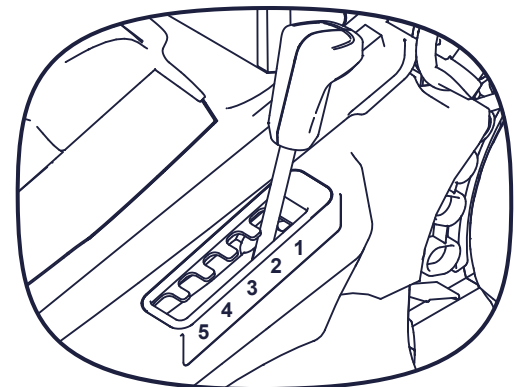

Cutting position	Cutting height
1	22mm
2	32mm
3	42mm
4	52mm
5	62mm

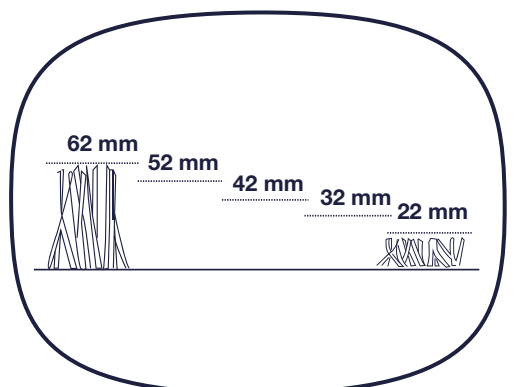

OPERATION

Switching on

- i. Press the button (1).
- ii. Pull the switch bar (2) towards the handle and hold in position.

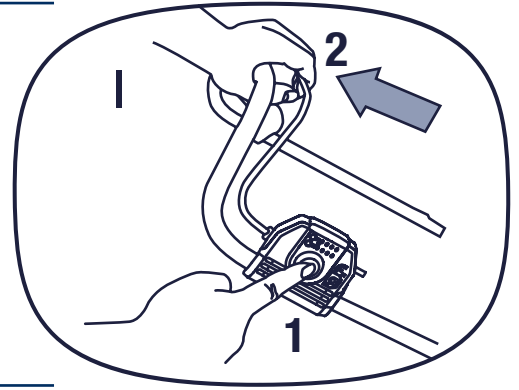

Switching off

Release the switch bar.

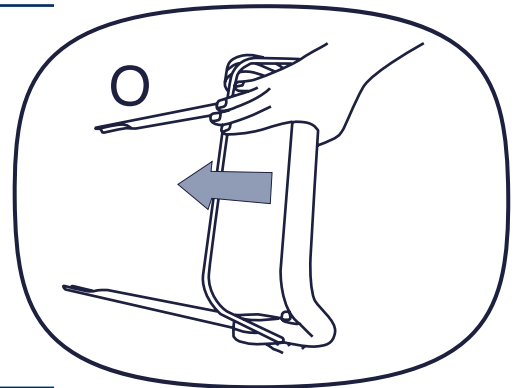

Grass bag full indicator

- i. If the collection bag is empty or it is not full with grass, the grass full indicator will open.

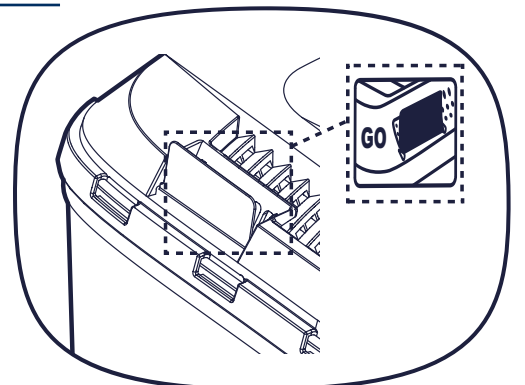

- ii. If the collection bag is full with grass, the grass full indicator will close.

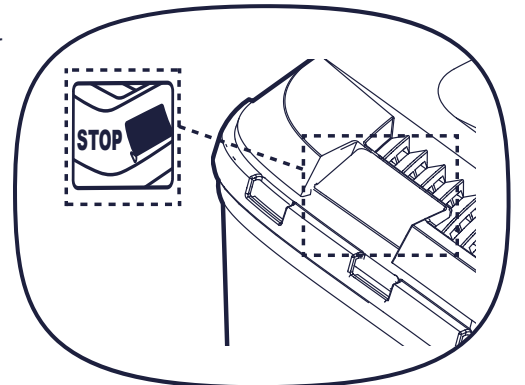

Battery indicator panel

- Battery indicator on the switch box can be used to indicate the battery status.
- Push the button to check on the battery status, 4 lights indicate a fully charged battery, 1 light indicates the battery needs to be charged.

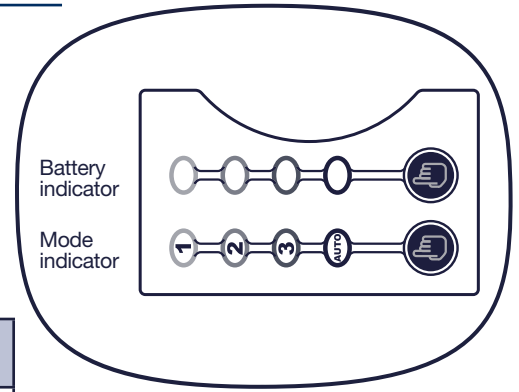

LED indicators on Panel	Battery Capacity
Continuous lighting of 4 LEDs (inc 2 green)	Fully charged
Continuous lighting of 3 LEDs (inc 1 green)	≥ 50%
Continuous lighting of 2 LEDs (orange & red)	≥ 25%
Continuous lighting of 1 LED (red only)	≤ 25%. Recharge required.

Mode indicator

- Push the press button repeatedly to cycle through the different motor power output levels.

Mode indicator on Panel	Motor power output level
AUTO	Automatically adjust to fit your lawn
1	Lawn needs only light mowing
2	Mow taller and thicker grass
3	Maximum motor power output, mow the most stubborn grass

Empty grass bag

- Lift the deflector guard and detach the grass collection bag.

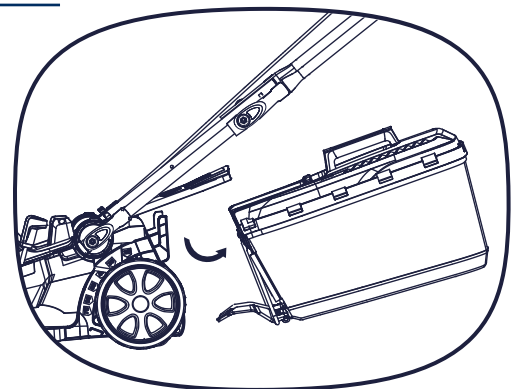

OPERATION

Using as a Mulcher

Do not attach the collection bag and the mulching plug at the same time.

The mulching plug allows the grass clippings to be deposited back on the lawn during cutting. To install plug:

- i. Lift the safety flap and detach the grass collection bag.
- ii. Lift and hold the safety flap up with one hand.
- iii. With other hand grasp plug by its upright handle and insert the plug into the rear discharge chute. Ensure that the locking latch snaps into place. The mulching plug **MUST** be removed if collection bag is used.
- iv. To remove the plug, lift and hold the safety flap up with one hand.
- v. With other hand squeeze the plug upright handle to release the locking latch. Pull the plug up and out of the discharge chute.

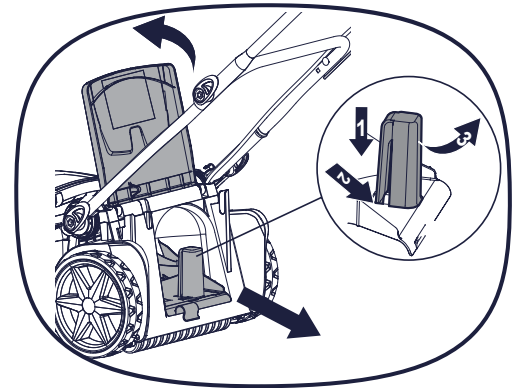
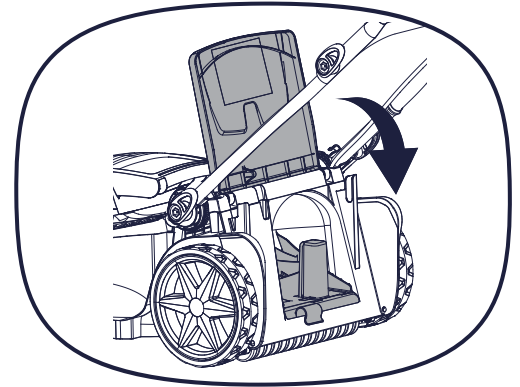
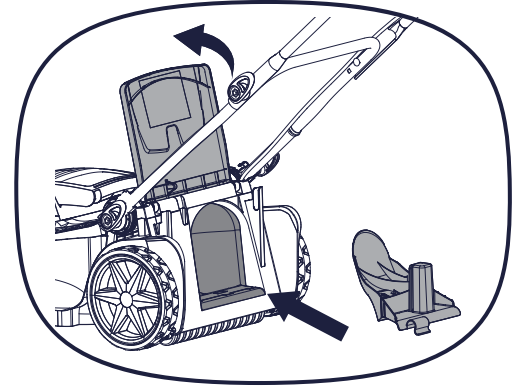



WARNING!

Always switch the product off, disconnect it from the power supply and let the product cool down before performing inspection, maintenance and cleaning work!

- i. Keep the underbody and cutting blade clean and free of debris. Remove clippings from the discharge chute.
- ii. Check all nuts and bolts periodically for tightness before operation. After prolonged use, especially in sandy soil conditions, the cutting blade will become worn and lose some of its original shape. The cutting efficiency will be reduced and the cutting blade should be replaced.
- iii. Lubricate the cutting blade after each use to prolong the life span of the cutting blade and product. Apply light machine oil along the edge of the cutting blade.

Replacing the cutting blade

Keep the cutting blade sharp to ensure a good cutting performance. Replace a worn or damaged cutting blade with a new one of the same type or have it sharpened by a qualified specialist.

- i. Loosen the bolt anticlockwise using a suitable wrench and remove it together with the blade.
- ii. Replace the blade with a new one of the same type.
- iii. Reattach the blade onto the spindle, pay attention to correct alignment. Tighten the bolt clockwise with 16 Nm min, 20 Nm max. to ensure safe operation of your product.

NOTE: Replace this cutting blade after 50 hours mowing or 2 years whichever is sooner regardless of condition.

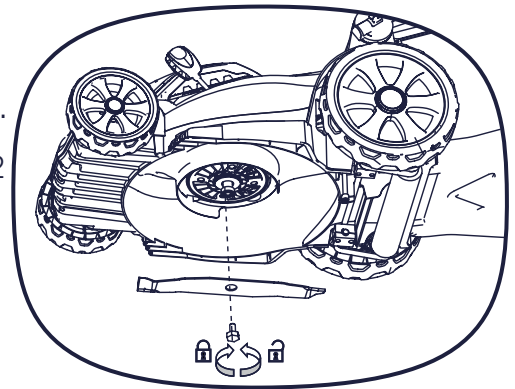

Storage



WARNING! To avoid damage to the cable, ensure the power cable is not caught between the folding sections.

- i. Switch the product off and remove the battery.
- ii. Clean the product as described above.
- iii. To reduce storage space, the upper handle can be folded down, turn the wing knobs anti-clockwise to loosen and release the handles.

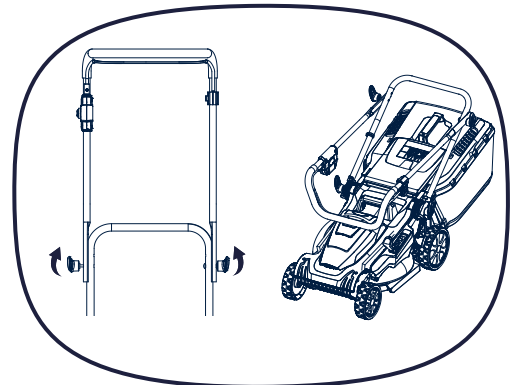

Transportation

- i. Switch the product off and remove the battery.
- ii. Protect the product from any heavy impact or strong vibrations which may occur during transportation in vehicles.
- iii. Secure the product to prevent it from slipping or falling over.



Recycling and disposal

This symbol is known as the Crossed out Wheelie Bin Symbol. When this symbol is marked on a product or battery, it means that it should not be disposed of with your general household waste. Some chemicals contained within electrical products or batteries can be harmful to health.

The packaging and the machine itself are manufactured from recyclable materials and should be disposed of accordingly.

Only dispose of electrical, electronic or battery powered products in separate collection schemes, which cater for the recovery and recycling of materials contained within.



Li-Ion batteries:

Please observe the instructions in section "Transport".

Do not dispose of with household waste.

Dispose of safely according to local legal requirements.

Due to a program of continuous product improvement features and instructions are liable to change without notice.

TECHNICAL DATA

Model	SCR3637A
Voltage	36V ---
No load speed	3100/min
Cutting width	37cm
Height of cut	22/32/42/52/62mm
Net weight	13.6 kg
Grass collector capacity	40 l

Charger	
Model no.	40LFC15
Charger input	220-240V 50/60Hz 145W
Charger output	40V --- 3.0A
Charging period (battery fully discharged)	60min
Permitted charging temperature range (for charger)	-5°C~50°C
Weight of charger	0.77kg
Insulation protection of charger	<input type="checkbox"/>

Battery pack	
Model no.	40LB4023-C
Nominal rated voltage of battery	36V ---
Capacity of battery	4.0Ah
Battery type	Lithium-Ion

Parts List	ACCESSORIES
211030014	Blade
211044113	Battery
211044114	Charger
211033123	Key
111221110	Mulching plug

TECHNICAL DATA

Sound values

Measured sound pressure level L_{pA} : 71.03 dB(A)

Measured sound power level L_{WA} : 91.03 dB(A)

Uncertainty K: 0.89 dB(A)

Guaranteed sound power level L_{WA} : 96 dB(A)

Vibration values

Hand arm vibration a_h : 3.369m/s²

Uncertainty K: 1.69m/s²

The sound values have been determined according to noise test code given in EN 60335-2-77, using the basic standards EN ISO 11201 and EN ISO 3744. The sound intensity level for the operator may exceed 80 dB(A) and ear protection measures are necessary.

The declared vibration value has been measured in accordance with a standard test method (according to EN 60335-2-77) and may be used for comparing one product with another. The declared vibration value may also be used in a preliminary assessment of exposure.



WARNING! Depending on the actual use of the product the vibration values can differ from the declared total! Adopt proper measures to protect yourself against vibration exposures! Take the whole work process including times the product is running under no load or switched off into consideration!

Proper measures include, among others, regular maintenance and care of the product and cutting attachments, keeping hands warm, periodical breaks and proper planning of work processes!

Produced in China under licence for Spear & Jackson. Argos Limited, 489-499 Avebury Boulevard, Milton Keynes, MK9 2NW. Argos (N.I.) Ltd, Forestside Shopping Centre, Upper Galwally, Belfast, United Kingdom, BT8 6FX. Argos Distributors (Ireland) Limited, Unit 7, Ashbourne Retail Park, Ballybin Road, Ashbourne, County Meath, Ireland

TROUBLESHOOTING

Suspected malfunctions are often due to causes that the user can fix themselves. Therefore, check the product using this section. In most cases the problem can be solved quickly.



WARNING! Only perform the steps described within these instructions! All further inspection, maintenance and repair work must be performed by a qualified specialist if you cannot solve the problem yourself!

Gloves and appropriate protective clothing must be worn when performing these operations. When inspecting the blade always remove the battery from the mower.

Fault	Possible Cause	Solution
Mower fails to operate	Possible clogging	Check underneath the mower and clear as necessary (always wear gardening gloves)
	Battery not fully charged	Charge battery
	Battery not inserted (properly)	Ensure battery is correctly inserted
	Grass too long	Increase height of cut and tilt garden product to reduce starting load
	Battery too hot/cold	Allow to cool/warm
	Isolator key not inserted correctly/fully	Fit key correctly
	There is a short delay in the motor starting after engaging the On/Off switch	This is normal. Hold On/Off switch for 1– 3secs to start motor.
Motor starts and stops immediately	Battery not fully charged	Charge battery
	Isolator key not inserted correctly/fully	Fit correctly
	Battery not inserted (properly)	Ensure battery is correctly inserted
	Battery too hot/cold	Allow to cool/warm Increase height of cut
Garden product functions intermittently	Motor protector has activated	Allow motor to cool and increase height of cut
Lawnmower leaves ragged cut	Height of cut too low	Increase height of cut
	Cutting blade blunt	Replace the blade
Poor cutting or motor labours	Possible clogging	Check underneath the mower and clear out as necessary (always wear thick gardening gloves)
	Blade fitted upside down	Refit blade correctly

TROUBLESHOOTING

Fault	Possible Cause	Solution
Area of cut (battery duration) not large enough	Height of cut too low	Increase height of cut and walk slower
	Grass too high	Increase height of cut and walk slower
	Grass wet or damp	Wait until grass is dry and walk slower
	Grass is dense	Increase height of cut, walk slower and cut more frequently
Cutting blade not rotating while garden product switched on	Cutting blade obstructed	Switch off garden product Clear obstruction (always wear gardening gloves)
	Blade nut/bolt loose	Tighten blade nut/bolt (17 Nm)
Excessive vibrations/noise	Blade nut/bolt loose	Tighten blade nut/bolt (17 Nm)
	Cutting blade damaged	Replace the blade
No charging procedure possible	Battery contacts contaminated	Clean the battery contacts (e.g. by inserting and removing the battery several times) or replace the battery
	The battery is defective, due to a disconnection in the battery (individual cells)	Replace the battery
The charge control LED do not light up after inserting the mains plug into the socket	Mains plug of battery charger not plugged in (properly)	Insert mains plug (fully) into the socket outlet
	Socket outlet, mains cable or battery charger defective	Check the mains voltage.

WARRANTY

If your device develops a fault, please don't hesitate to contact our after sales support on 0345 605 2068, the majority of problems can be solved directly on the phone.

1. These warranty terms cover additional warranty rights and do not affect your statutory warranty rights. This product is covered by a 3 year manufacturer warranty.
2. Claims must be accompanied by proof of purchase. This must be in the form of a Sales receipt or bank statement and must show that the product has been purchased within the warranty period as described under point 1, from the retailer that it was originally bought from. Please keep your receipt safe or staple it to the back of this manual for future reference.
3. Our devices have not been designed for commercial, trade or industrial applications, any signs of use of the equipment in these application or equivalent activities, invalidates the warranty.
4. The following are also excluded from our warranty:
 - A. Faults due to accidents, customer misuse or unauthorised repairs
 - B. Consumable Parts such as blades, wing knobs, grass bags and other accessories that are compatible with the product.
 - C. Failure due to lack of routine maintenance.
 - D. Failure as a result of not using the equipment in accordance with the manual and safety instructions

Warranty claims should be submitted before the end of the warranty period, see point 1. The original warranty period remains applicable to the device even if repairs are carried out or parts are replaced. In such cases, the work performed or parts fitted will not result in an extension of the warranty period, and no new warranty will become active for the work performed or parts fitted.

If you have any problems or questions concerning your garden power tool, please contact our after sales support at 0345 605 2068.