

# TOWER®

over 100 YEARS of quality

T17038

5-in-1  
Manual  
Air Fryer  
Oven with  
Rotisserie



**3** YEAR  
GUARANTEE



GREAT BRITISH  
DESIGN SINCE 1912

SAFETY AND INSTRUCTION MANUAL  
PLEASE READ CAREFULLY

\*Subject to registering your Extended Guarantee online at [www.towerhousewares.co.uk](http://www.towerhousewares.co.uk).



## Towerbrand

GREAT BRITISH DESIGN, INNOVATION  
AND EXCELLENCE SINCE 1912

Since the turn of the 20th century, Tower has been designing, developing and manufacturing housewares and small appliances used by millions of households throughout the UK and beyond. During the 1960s, the rise in popularity of pressure cooking saw Tower become the UK's largest producer of pressure cookers, right through into the late 1980s. In recent years the Tower brand has been reborn with an exciting and varied range of housewares and electrical appliances that have quickly reinstated the brand's richly deserved status as a household name.

# TOWER

Visit

[www.towerhousewares.co.uk](http://www.towerhousewares.co.uk)

for more fantastic products.

Thank you for purchasing this appliance from the Tower range.

Please read this manual carefully **BEFORE** using the appliance for your own safety.

It has been designed to provide many years of trouble-free use.

**There are many benefits to using a Tower Air Fryer**

- Easy-to-use multi-function controls
- Extra-large 11L frying capacity – ideal for family meals.
- Adjustable temperature control from 80° – 200°, to suit a variety of meals.
- 60-minute timer with automatic shut-off feature, for accurate and precise cooking.
- Rapid air circulation system to cook food fast and save energy.
- Healthy alternative to cooking deep fried food with no oil.
- Air fried food retains its nutritional value, but still has the taste of delicious fried food.

## Contents:

1. **Specifications**  
Components and structure
2. **Technical Data**
3. **Important Safety Information**
4. **Before First Use**
5. **Using your Appliance**
6. **Troubleshooting**
7. **Recycling**
8. **Cleaning & Care**
9. **Wiring Safety**
10. **Warranty Information**
11. **Weights and Measures**
12. **Recipes**

See back page for Customer Service Information.

**Call us first, we can help.**

With advice, spares and returns.

Visit our website: [towerhousewares.co.uk](http://towerhousewares.co.uk) Call: +44 (0)333 220 6066  
(8.30am to 6.00pm Monday-Friday)

# 1 - Specifications:

**This box contains:**  
Instruction Manual  
Tower Air Fryer  
Air Flow Racks x 3  
Roasting Spit  
Handle  
Drip Tray



## Structure of your appliance:

- |                             |                   |
|-----------------------------|-------------------|
| 1. Timer control dial       | 4. Housing        |
| 2. Power ON/OFF button      | 5. Drip Tray      |
| 3. Temperature control dial | 6. Removable Door |

## 2 - Technical Data:

Description:	5-in-1 Manual Air Fryer Oven with Rotisserie
Model:	T17038
Rated Voltage:	220-240V
Frequency:	~50/60Hz
Power Consumption:	2000W

### Documentation

We declare that this product conforms to the following product legislation in accordance with the following directive(s):

2014/30/EU	Electromagnetic Compatibility Directive.
2014/35/EU	Low Voltage Directive.
2011/65/EU	Restriction of Hazardous Substances Directive.
1935/2004/EC	Materials & Articles in Contact With Food (LFGB section 30 & 31).
2009/125/EC	Eco-Design of Energy Related Products.

RK Wholesale LTD Quality Assurance, United Kingdom.

Should you encounter problems or require a replacement part, contact the Tower Customer Support Team: **+44 (0) 333 220 6066**.

Some spare parts may be ordered from the Tower website.  
Your warranty becomes void should you decide to use non Tower spare parts.  
Spare parts can be purchased from **[www.towerhousewares.co.uk](http://www.towerhousewares.co.uk)**

### Guarantee for spare parts:

The spares and accessories are guaranteed for 1 year from date of purchase.  
The main body and housing are guaranteed for the extended free warranty subject to registration.  
If any defect arises due to faulty materials of workmanship, the faulty products must be returned to the place of purchase within 12 months from the date of purchase.  
Refund or replacement is at the discretion of the retailer.

### 3 - Important Safety Information:

Please read these notes carefully BEFORE using your Tower appliance

- Check that the voltage of the main circuit corresponds with the rating of the appliance before operating.
- If the supply cord or appliance is damaged, stop using the appliance immediately and seek advice from the manufacturer, its service agent or a similarly qualified person.
- **WARNING! DO NOT** let the cord hang over the edge of a table or counter, serious burns may result from the air fryer being pulled off the counter where it may be grabbed by children or become entangled with the user.
- **DO NOT** carry the appliance by the power cord.
- **DO NOT** use any extension cord with this appliance.
- **DO NOT** pull the plug out by the cord as this may damage the plug and/or the cable.
- Switch off at the wall socket then remove the plug from the socket when not in use or before cleaning.
- Switch off and unplug before fitting or removing tools/ attachments, after use and before cleaning.
- Close supervision is necessary when any appliance is used by or near children.
- Children should not play with the appliance.
- This appliance can be used by children aged from 16 years and above and persons with reduced physical, sensory or mental capabilities or lack of experience and knowledge if they have been given supervision or instruction

concerning use of the appliance in a safe way and understand the hazards involved.

- Cleaning and user maintenance should not be undertaken by children without supervision.
- Take care when any appliance is used near pets.
- DO NOT use this product for anything other than its intended use.
- This appliance is for household use only.
- This appliance includes a heating function. Please ensure that the appliance is used on a stable, level, and heat resistant surface.
- DO NOT immerse cords, plugs or any part of the appliance in water or any other liquid.
- DO NOT use the appliance outdoors.
- DO NOT place the air fryer on or near combustible materials such as a tablecloth or curtain.
- DO NOT place the air fryer against a wall or against other appliances. Leave at least 10cm free space on the back and sides and 10cm free space above the appliance.
- Allow the air fryer to cool down for approximately 30 minutes before you handle or clean it.
- Make sure the food prepared in the air fryer comes out golden-yellow instead of dark brown. Remove burnt remnants.
- During hot air frying, hot steam is released through the air outlet openings. Keep your hands and face at a safe distance from the steam and from the air outlet openings.
- Hot steam and air may escape when you open air fryer.

- Any baking trays or oven dishes used in the air fryer will become hot. Always use oven gloves when handling or removing anything from the air fryer.
- **WARNING! DO NOT** fill the air fryer with oil as this may cause a fire hazard.
- Ensure that all ingredients are spaced well in the fryer.
- **DO NOT** place anything on top of the air fryer.
- In the unlikely event the appliance develops a fault, stop using it immediately and seek advice from the Customer Support Team:  
+44 (0) 333 220 6066



## 4 - Before First Use

Read all instructions and safety information carefully before first use. Please retain this information for future reference.

1. Remove your appliance from the packaging.
2. Check that there is no damage to the cord or any visible damage to the body.
3. Dispose of the packaging in a responsible manner.
4. Remove any stickers or labels from the appliance
5. Thoroughly clean the fryer with hot water, some washing-up liquid and a non-abrasive sponge.
6. Wipe the inside and outside of the appliance with a moist cloth.
7. Do not fill the fryer with oil or frying fat. This is fryer operates using hot air and requires very little to no oil.

## 5 - Using Your Appliance

### Removing the door:

1. The air fryer has a removable door, which can be pulled apart from the appliance for easier cleaning.
2. To separate the door from the air fryer, push the door as far down as it will go (about 70 degrees), then push the grooved latch on the right-hand side of the hinge horizontally to release the door. Once the door has been released, pull it downward to separate it from the body of the fryer.
3. To reinstall the door, align the edges of the door with the holes on either side of the hinge, and insert it as shown in the images below.



### Automatic Switch Off:

The Tower Air Fryer has a built in timer, which will automatically shut off the air fryer when the timer reaches zero.

You can manually switch off the air fryer by turning the temperature control dial counter-clockwise until it reaches zero. You will hear a ringing sound to indicate the timer is at zero.

### Preparing For Use:

1. Place the appliance on a stable, horizontal and even surface. Do not place the appliance onto a non-heat-resistant surface.
2. Pull the cord from the storage compartment located at the bottom of the appliance.
3. Do not fill the fryer with oil or any other liquid.
4. Do not put anything on top of the appliance, as this will disrupt the airflow and the hot air frying will be affected as a result.

### Air Frying:

1. Connect the mains plug into an earthed wall socket.
2. Open the air fryer door.
3. Put the ingredients into the air fryer.
4. Close the air fryer door.
5. Determine the required preparation time for your desired ingredients (refer to the 'Settings' section below).
6. To switch on the appliance, turn the timer dial to the required preparation time.
7. Turn the temperature control dial to the required temperature. Refer to the 'Settings' section in this chapter to learn how to determine the right temperature. Add 2 minutes to the preparation time when the appliance is cold.

8. When using the rotisserie or grilling rack, touch the  switch. The fryer's internal light will illuminate and the rotisserie will begin to rotate. Rotation will stop automatically and the internal light will go off whenever the cooking process is finished.

						
200°C 15-20min	200°C 18-20min	200°C 18-20min	200°C 30-40min	200°C 18-25min	180°C 10-15min	180°C 20-30min

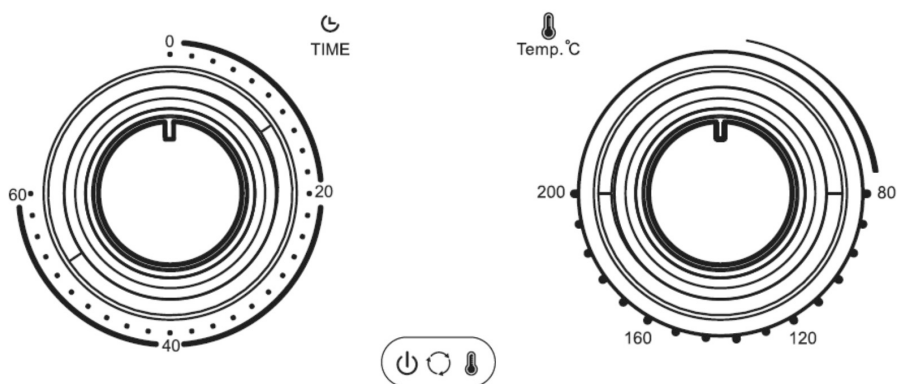

- The timer starts counting down the set preparation time.
- During the air frying process, the working light will turn on and off from time to time. This indicates that the heating element is being switched on and off to maintain the set temperature.
- Excess oil from the ingredients is collected on the bottom of the drip tray.

**Note:** During the frying process, food will get very hot and steam may escape from the air fryer.

10. When you hear the timer bell, the set preparation time has elapsed.

**Note:** You can also switch the appliance off manually at any time by turning the temperature control dial to zero.

- Check if the ingredients are ready. If the ingredients are not ready yet, simply place your food back into the fryer, close the door, then set the timer to a few extra minutes.
- To remove ingredients (e.g. fries), open the air fryer door and pull out the food using the insulated kitchen gloves or other suitable safety accessory such as tongs.
- When a batch of ingredients is ready, the air fryer is instantly ready for preparing another batch.

### Timer:

The Air Fryer has a 60 minute manual timer with a bell. Turn the dial to the required cooking time. When the cooking time has elapsed, a bell will sound to indicate that the cooking has finished.

### Temperature Selection:

To manually select the correct temperature for each dish, turn the temperature control dial on the unit's control panel.

The air fryer will automatically start cooking once a temperature has been set.

### Settings:

The table on the next page will help you to select the basic settings for the ingredients.

**Note:** Keep in mind that these settings are indications, as ingredients differ in origin, size, shape and brand, we cannot guarantee the best settings for your ingredients. Because the Rapid Air technology instantly reheats the air inside the appliance instantly, opening the door briefly during hot air frying barely disturbs the process.

### Tips:

- The preparation time will depend on the size of your ingredients. Smaller sizes may require a shorter cooking time.
- Add some oil to fresh potatoes for a crispy result. Fry your ingredients in the Hot-air fryer within a few minutes after you added the oil.
- Be cautious of using extremely greasy ingredients such as sausages in the air fryer.
- Snacks that can be prepared in an oven can also be prepared in the air fryer.
- The optimal amount for preparing crispy fries is 700 grams.
- Use pre-made dough to prepare filled snacks quickly and easily. Pre-made dough also requires a shorter preparation time than home-made dough.
- Place a baking tin or oven dish if you want to bake a cake or quiche, or if you want to fry fragile ingredients or filled ingredients.
- You can also use the air fryer to reheat ingredients. To reheat ingredients, set the temperature to 150°C for up to 10 minutes.

### Settings Table:

	Min-max Amount (g)	Time (min.)	Temperature (°C)	Extra information
<b>Potato &amp; fries</b>				
Thin frozen fries	600-700	15-20	200	
Thick frozen fries	600-700	20-25	200	
Potato gratin	800-1000	25-30	200	
<b>Meat &amp; Poultry</b>				
Steak	500-800	10-15	180	
Pork chops	500-800	10-15	180	
Hamburger	400-800	10-15	180	
Sausage roll	400-800	13-15	200	
Drumsticks	400-800	25-30	180	
Chicken breast	400-800	15-20	180	
Rotisserie	400-600	18-25	200	
Chicken	500-1000	30-40	200	
<b>Snacks</b>				
Spring rolls	500-800	8-10	200	Use oven-ready
Frozen chicken nuggets	500-1000	6-10	200	Use oven-ready
Frozen fish fingers	500-800	6-10	200	Use oven-ready
Frozen bread crumbed cheese snacks	500-800	8-10	180	Use oven-ready
Stuffed vegetables	400-800	10	160	
<b>Baking</b>				
Cake	800	20-25	160	Use baking tin
Quiche	800	20-22	180	Use baking tin/ oven dish
Muffins	800	15-18	200	Use baking tin
Sweet snacks	800	20	160	Use baking tin/ oven dish



### Using the accessories:

This air fryer comes complete with a range of accessories:

- Drip tray, to help collect fat and drippings for easy cleaning.
- Air flow racks, suitable for dehydrating, crisping or reheating food items.
- Roasting spit, for use with roast meat or fish.
- Handle, for safely retrieving the above accessories from the fryer after cooking.

### Assembling the Roasting Spit:

1. To assemble the roasting spit, first slide the shaft through the corresponding slots on either of the roasting forks, so that the forks are on the inside of the shaft.
2. Retrieve the two small keys provided with the unit and thread each of them through its corresponding hole on the spit forks. Rotate each key clockwise to tighten it and secure the forks to the main body of the shaft. Rotate each key counter-clockwise to loosen it, so that it sits loosely on its corresponding slot or can be removed if desired.
3. Once you have loosened each of the two keys, slot the spit shaft into the recessed gear notch on the left-hand side of the oven cavity and the locating bracket on the right-hand side, ensuring it is pushed in all the way. When it has been correctly fitted to the gear and bracket, insert the keys back into each of their respective slots and turn them clockwise to tighten them and secure the shaft into place.
4. Your roasting spit is now ready for use.

### Using the Roasting Spit:

To use the roasting spit, align the two nuts on either side of the spit shaft with the recessed gear notch on the left-hand side of the oven cavity and the locating bracket on the right-hand side. Slide the left-hand end of the spit roast along the fryer wall until it slots into place inside the gear notch, then place the other end onto the locating bracket. Ensure both ends are firmly secured into place before attempting to use the spit roast.

**Note:** Ensure the shaft nut is pushed all the way into the gear slot and that no part of it is visible to the naked eye; otherwise the spit will not rotate.

- Once you have installed the spit, press the  key in the unit's control panel to activate the rotation function. If the spit has been installed correctly, it will begin to rotate.
- If the spit does not begin to rotate once the button has been pressed, pull it out of the air fryer and repeat the steps detailed above, taking care to ensure the shaft nut is pushed all the way into the slot on the body of the fryer.



## 6 - Troubleshooting

Problem	Possible cause	Solution
The air fryer does not work	The appliance is not plugged in.	Plug the appliance into an earthed wall socket.
	The timer is not set.	Turn the timer dial to the required preparation time to switch on the appliance.
The fried ingredients are not done.	The amount of ingredients is too big.	Put smaller batches of ingredients in the air fryer. Smaller batches are fried more evenly.
	The set temperature is too low.	Turn the temperature control dial to the required temperature setting (refer to the 'Settings' section under 'Using the appliance' for a temperature reference guide.)
	The preparation time is too short.	Turn the timer dial to the required preparation time (refer to the 'Settings' section under 'Using the appliance' for a timer reference guide.)
Fried snacks are not crispy when they come out of the air fryer.	Wrong type of snacks used.	Use oven snacks or lightly brush some oil onto the snacks for a crispier result.
	The fryer contains grease from previous use.	White smoke is caused by grease heating up inside the fryer. Make sure you clean the fryer properly after each use.
Fresh fries are fried unevenly in the air fryer.	Wrong type of potatoes used.	Use fresh potatoes and make sure they stay firm during frying.
	The potato sticks were not rinsed adequately before frying.	Rinse the potato sticks properly to remove starch from the outside.
Fresh fries are not crispy when they come out of the air fryer.	The crispiness of the fries depends on the amount of oil and water in the fries.	Make sure you dry the potato sticks properly before you add the oil.
		Cut the potato sticks smaller for a crispier result.
		Add slightly more oil for a crispier result.

## 7 - Recycling

### DISPOSAL OF THE UNIT

Appliances bearing the symbol shown here may not be disposed of in domestic rubbish. You are required to dispose of old electrical and electronic appliances like this separately.

Please visit [www.recycle-more.co.uk](http://www.recycle-more.co.uk) or [www.recyclenow.co.uk](http://www.recyclenow.co.uk) for access to information about the recycling of electrical items.

Please visit [www.weeeireland.ie](http://www.weeeireland.ie) for access to information about the recycling of electrical items purchased in Ireland.

The WEEE directive, introduced in August 2006, states that all electrical items must be recycled, rather than taken to landfill.

Please arrange to take this appliance to your local Civic Amenity site for recycling, once it has reached the end of its life.





## 8 - Cleaning & Care

WARNING! DO NOT IMMERSE THE APPLIANCE IN WATER OR ANY OTHER LIQUID.

- Clean the appliance after every use.
  - Do not use metal kitchen utensils or abrasive cleaning materials to clean the drip tray, as this may damage the non-stick coating.
1. Remove the mains plug from the wall socket and let the appliance cool down.

**Note:** Open the door to let the air fryer cool down more quickly.

2. Wipe the outside of the appliance with a moist cloth.
3. Clean the drip tray and accessories with hot water, some washing-up liquid and a non-abrasive sponge.
4. You can use degreasing liquid to remove any remaining dirt.
5. Clean the inside of the appliance with hot water and a non-abrasive sponge.

### **Storage:**

To store your appliance:

1. Ensure that the air fryer is cool, clean and dry before storing it.
2. Store the appliance in a cool, dry place.
3. Store on a flat, dry level surface out of reach of children.

## 9 - Wiring Safety for UK Use Only

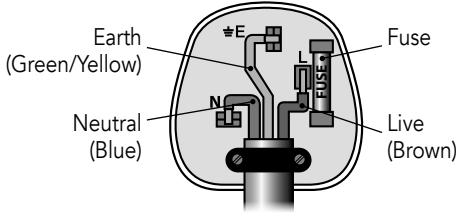

### IMPORTANT

As the colours in the mains lead of this appliance may not correspond with the coloured markings identifying the terminals in your plug, please proceed as follows:

The wires in the mains lead are labelled in accordance with the following code:

Blue neutral [N] Brown live [L]  
Green/Yellow [EARTH] 

Plug Fitting Details (Where Applicable). The wire labelled blue is the neutral and must be connected to the terminal marked [N].

The wire labelled brown is the live wire and must be connected to the terminal marked [L].

The wire labelled green/yellow must be connected to the terminal marked with the letter [E].

On no account must either the brown or the blue wire be connected to the [EARTH] terminal.

Always ensure that the cord grip is fastened correctly.

The plug must be fitted with a fuse of the same rating already fitted and conforming to BS 1362 and be ASTA approved.

If in doubt consult a qualified electrician who will be pleased to do this for you.

### Non-Rewireable Mains Plug

If your appliance is supplied with a non-rewireable plug fitted to the mains lead and should the fuse need replacing, you must use an ASTA approved one (conforming to BS 1362 of the same rating).

If in doubt, consult a qualified electrician who will be pleased to do this for you.

If you need to remove the plug - disconnect it from the mains - then cut it off of the mains lead and immediately dispose of it in a safe manner. Never attempt to reuse the plug or insert it into a socket outlet as there is a danger of an electric shock.

**WARNING:**  
This appliance **MUST** be earthed!

## 10 - Warranty

**3\*** | YEAR  
GUARANTEE



**GREAT BRITISH**  
DESIGN SINCE 1912

As a thank you for purchasing one of our fantastic products, we are offering you an extra 2 years peace of mind in addition to your 1 year guarantee.

To receive your extra 2 year guarantee, register your appliance online within 28 days of purchase by visiting [www.towerhousewares.co.uk](http://www.towerhousewares.co.uk)



This product is guaranteed for 12 months from the date of original purchase. If any defect arises due to faulty materials of workmanship, the faulty products must be returned to the place of purchase. Refund or replacement is at the discretion of the retailer.

### The Following Conditions Apply:

- The product must be returned to the retailer with proof of purchase or a receipt.
- The product must be installed and used in accordance with the instructions contained in this instruction guide.
- It must be used only for domestic purposes.
- It does not cover wear and tear, damage, misuse or consumable parts.
- Tower has limited liability for incidental or consequential loss or damage.

This guarantee is valid in the UK and Eire only.

The standard one year guarantee is only extended to the maximum available for each particular product upon registration of the product within 28 days of purchase. If you do not register the product with us within the 28 day period, your product is guaranteed for 1 year only.

To validate your extended warranty, please visit [www.towerhousewares.co.uk](http://www.towerhousewares.co.uk) and register with us online.

Please note that length of extended warranty offered is dependent on product type and that each qualifying product needs to be registered individually in order to extend its warranty past the standard 1 year. Extended warranty is only valid with proof of purchase or receipt.

# 11 - Weights & Measures

Check these charts for basic imperial to metric conversions of weights.

Metric	Imperial	US cups
250ml	8 floz	1 cup
180ml	6 fl oz	3/4 cup
150ml	5 floz	2/3 cup
120ml	4 floz	1/2 cup
75ml	2 1/2 floz	1/3 cup
60ml	2 floz	1/4 cup
30ml	1 floz	1/8 cup
15ml	1/2 floz	1 tablespoon

Imperial	Metric
1/2 oz	15g
1 oz	30g
2 oz	60g
3 oz	90g
4 oz	110g
5 oz	140g
6 oz	170g
7 oz	200g
8 oz	225g
9 oz	255g
10 oz	280g
11 oz	310g
12 oz	340g
13 oz	370g
14 oz	400g
15 oz	425g
1 lb	450g

## Food Allergies

Important Note: Some of the recipes contained in this document may contain nuts and/or other allergens. Please be careful when making any of our sample recipes that you ARE NOT allergic to any of the ingredients. For more information on allergies, please visit the Food Standards Agency's website at: [www.food.gov.uk](http://www.food.gov.uk)



# TOWER<sup>®</sup>

Recipes

Recipes for use with the T17038  
5-in-1 Manual Air Fryer Oven with Rotisserie  
For more great recipes and inspiration from the  
Tower Kitchen, visit  
[www.towerhousewares.co.uk/blog](http://www.towerhousewares.co.uk/blog)

## Homemade Fries

### Ingredients

2 large potatoes  
½ tbsp. paprika  
Pinch of salt  
Pinch of pepper  
1 tbsp. Sunflower oil  
Ingredients  
1 free range egg  
1 strip of bacon  
1 English muffin  
Cheese to slice  
Pinch of pepper and salt to taste

### Method

1. Wash, peel and slice the potatoes.
2. Dry with kitchen paper.
3. Cut the potatoes into your desired length and thickness.
4. Bring a large pot of water to the boil with a pinch of salt. Add the chips and allow to part boil for 10 minutes.
5. Strain the fries and immediately run under cold water to stop them from cooking any more.
6. Pour the oil in a bowl, with the paprika, salt and pepper. Put the fries on top and mix until all the fries are coated.
7. Remove the fries from the bowl with your fingers or kitchen utensil so that the excess oil stays behind in the bowl.
8. Place the fries in the air fryer, and then set the time & temperature as shown on the reference table.

**Variations:** Try replacing ½ tbsp. of paprika with ½ tbsp. garlic powder, or ½ tbsp. of grated parmesan cheese.

## Bacon and Egg Breakfast Muffin

### Ingredients

1 free range egg  
1 strip of bacon  
1 English muffin  
Cheese to slice  
Pinch of pepper and salt to taste

### Method

1. Crack the egg into a small ramekin or oven proof dish.
2. Cut the English muffin in half and layer cheese on one half.
3. Place the muffin, bacon and egg (in the ramekin) into the Air Fryer.
4. Turn the Air Fryer to 200°C for 6 minutes.
5. Once it's cooked, assemble your breakfast muffin and enjoy.

**Tip:** Try adding some mustard on the muffin for extra flavour.

# Traditional Grilled Cheese

Makes 2 sandwiches

## Ingredients

2 slices of bread  
2 slices of prosciutto  
2 slices of tomato  
2 slices of mozzarella cheese  
2 basil leaves  
½ pinch of salt & pepper  
1 tsp. of olive oil

## Method

1. Lay prosciutto and mozzarella cheese on top of one slice of bread. Add the second slice of bread on top, making a sandwich.
2. Put the sandwich into your Air Fryer for 5 minutes at 200°C
3. Once the timer bell has rung, carefully remove the sandwich.
4. Remove the top slice of bread and drizzle the tsp. of olive oil over the mozzarella.
5. Add the pinch of salt and pepper to season and top with tomato and basil.
6. Put the second slice of bread on top and serve.

# TOWER®

over 100 YEARS of quality

## *thank you!*

We hope you enjoy your appliance for many years. As a thank you for purchasing one of our fantastic products, we are offering you an extra 2 years peace of mind.

\*To receive your extra 2 years guarantee, register your appliance online within 28 days of purchase by visiting:

[www.towerhousewares.co.uk](http://www.towerhousewares.co.uk)

Should you have a problem with your appliance, or need any spare parts, please call our Customer Support Team on:

+44 (0) 333 220 6066

Your warranty becomes void should you decide to use non Tower spare parts. Spare parts can be purchased from [www.towerhousewares.co.uk](http://www.towerhousewares.co.uk)

