

# BUSH

## Instruction manual

Bush Upright Vacuum Cleaner

Model: VUS34AE20



You'll soon be enjoying your new Bush Upright Vacuum Cleaner

It all begins here, with your instructions. Don't worry, there's nothing too technical coming up. Just simple, step-by-step guidance to get you up and running quickly. Sound good? Then let's get started.

## Help and Guidance

We're here to help you get the most from your Bush Upright Vacuum Cleaner.

Should you require any guidance; call our Help line on 0345 604 0105. Further contact details can be found online at: [www.bush-support.co.uk](http://www.bush-support.co.uk)

# Contents

<b>1</b>	<b>Safety information</b>	
	Power source	6
	Ventilation heat and moisture	7
	Warning	8
	Plug / Wiring advice	9
<b>2</b>	<b>Getting to know your vacuum cleaner</b>	
	Accessories	12
	Part identification	13
<b>3</b>	<b>Assembling your vacuum cleaner</b>	
	Assembly	16
<b>4</b>	<b>Using your vacuum</b>	
	Operating the appliance	18
	How to use accessories	19
	Nozzle use	19
<b>5</b>	<b>Care and maintenance</b>	
	Maintenance	22
	Emptying the dust container	22
	Cleaning the filters	23
	How to clear a blockage	24
	How to maintain brush roll bar	25
	How to replace brush roll bar or belt	26
	Other information	28
	Recycling electrical products	28
<b>6</b>	<b>Product support</b>	
	Troubleshooting	30
	Help and assistance	31
	Guarantee	32

If you require any technical guidance or find that your product is not operating as intended, a simple solution can often be found in the **Troubleshooting** section of these instructions

# Safety information

# 1





## **Safety information**

**Important** - Please read these instructions fully before assembling or operating

FOR HOUSEHOLD USE ONLY.

When using the vacuum cleaner, basic safety precautions should always be observed, including the following:

- Only use the vacuum cleaner indoors on dry surfaces. Do not handle the plug or vacuum cleaner with wet hands. Do not use outdoors or on wet surfaces.
- Turn off the vacuum cleaner controls before disconnecting or connecting from the mains supply.
- Always unplug the vacuum cleaner before connecting or disconnecting the vacuum hose and accessories.
- Children should be supervised to ensure that they do not play with the appliance.
- This appliance can be used by children aged from 8 years and above and persons with reduced physical, sensory or mental capabilities or lack of experience and knowledge if they have been given supervision or instruction concerning use of the appliance in a safe way and understand the hazards involved.
- Only use as described in this manual. Only use recommended attachments.
- Do not use the vacuum cleaner if it has been dropped, damaged, left outdoors or dropped into water.
- Do not use the vacuum cleaner with a damaged cord or plug. If the supply cord is damaged, please consult qualified technician in order to avoid hazard.
- Do not pull or carry by cord. Do not use the cord as a handle, close a door on the cord or pull cord around sharp edges or corners. Do not run the vacuum cleaner over the cord. Keep

If you require any technical guidance or find that your product is not operating as intended, a simple solution can often be found in the **Troubleshooting** section of these instructions



## Safety information

**Important** - Please read these instructions fully before assembling or operating

the cord away from heated surfaces.

- Do not put any objects into openings. Do not use with any openings blocked and do not restrict air-flow. Keep all openings free of dust, lint, hair or anything that might reduce airflow.
- Keep hair, loose clothing, fingers and all parts of the body away from openings and moving parts.
- Do not pick up hot coals, cigarette butts, matches or any hot, smoking or burning objects.
- Do not pick up flammable or combustible materials (lighter fluid, petrol, kerosene etc.) or use in the presence of explosive liquids or vapours.
- Do not vacuum up harmful or toxic material (chlorine, bleach, ammonia, drain cleaner etc.).
- Do not vacuum up hard or sharp objects such as glass, nails, screws, coins, etc.
- Do not use without all of the filters in place.
- Take extra care when vacuuming on stairs.
- Keep vacuuming area well lit.
- Store the vacuum cleaner in a cool, dry area.
- Turn off the on/off switch before unplugging the vacuum cleaner.
- Only use CE-approved 13 amp extension cords. Non-approved cords may overheat. Care should be taken to arrange the cord so that the cord cannot be tripped over.



## Safety information

**Important** - Please read these instructions fully before assembling or operating

**WARNING:** Always switch o° and unplug the vacuum cleaner from the electrical outlet before assembling, opening or emptying the dirt container, connecting/ disconnecting the attachments, or carrying out maintenance or troubleshooting checks.

**CAUTION:** The vacuum cleaner is a very powerful unit. Before plugging the cord into the electrical outlet, make sure the switch is in the 'o°' position. Hold the vacuum cleaner firmly when starting and in use.

**IMPORTANT:** If the inlet, hose or extension tube is blocked, switch o° the vacuum cleaner and remove the blockage(s) before re-starting the vacuum cleaner.

**IMPORTANT:** We recommend that filters should be checked and cleaned periodically. For washable filters, ensure they are completely dry before inserting back into the vacuum cleaner. Do not wash with detergents. Only use warm water, max 40°C.

PLEASE KEEP INSTRUCTIONS  
FOR FURTHER USE





## Safety information

**Important** - Please read these instructions fully before assembling or operating

### Plug / Wiring advice

The wires in this mains lead are coloured in accordance with the following UK electrical code:

BLUE = NEUTRAL

BROWN = LIVE

### Non-rewireable plug

This appliance may be fitted with a “non-rewireable” plug. If you need to change the fuse in a “non-rewireable” plug, fuse cover must be refitted. If the fuse cover is lost or damaged, the appliance must not be used.

### Rewireable plug

The colours of the wires in the mains lead of this appliance may not correspond with the coloured markings identifying the terminals in a rewireable plug. **Rewireable plugs should only be replaced by a suitably competent person. If in doubt, consult a qualified electrician in order to avoid hazard.**

Should the fuse need to be replaced, a 13 amp fuse approved to BS1363/A must be used

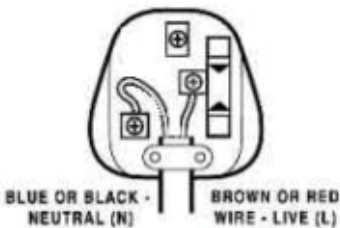

The BLUE wire must be connected to the terminal marked with the letter N

The BROWN wire must be connected to the terminal marked with the letter L

If you require any technical guidance or find that your product is not operating as intended, a simple solution can often be found in the **Troubleshooting** section of these instructions

**Getting to know your vacuum cleaner**

**2**



# Getting to know your vacuum

You'll be up and running in no time

## Ready? Let's begin...

Please read these instructions carefully. They contain important information which will help you get the best from your Vacuum cleaner and ensure safe and correct installation and operation.

If you require any further assistance, our technical experts are happy to help. For full details, refer to the product support section at the end of these instructions.

## Accessories

Accessories: long Crevice tool, Brush tool, upholstery tool.

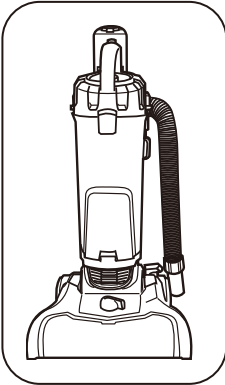

Vacuum cleaner

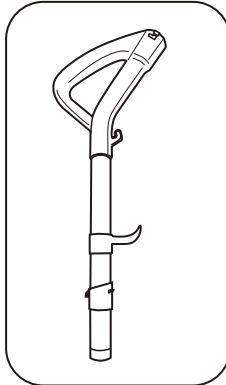

Handle

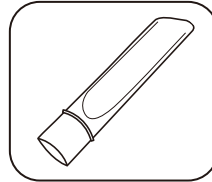

Crevice tool

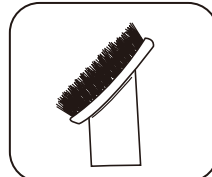

Dusting brush

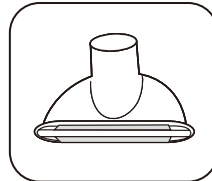

Upholstery tool

If you require any technical guidance or find that your product is not operating as intended, a simple solution can often be found in the

**Troubleshooting** section of these instructions

# Getting to know your vacuum

You'll be up and running in no time

## Part identification

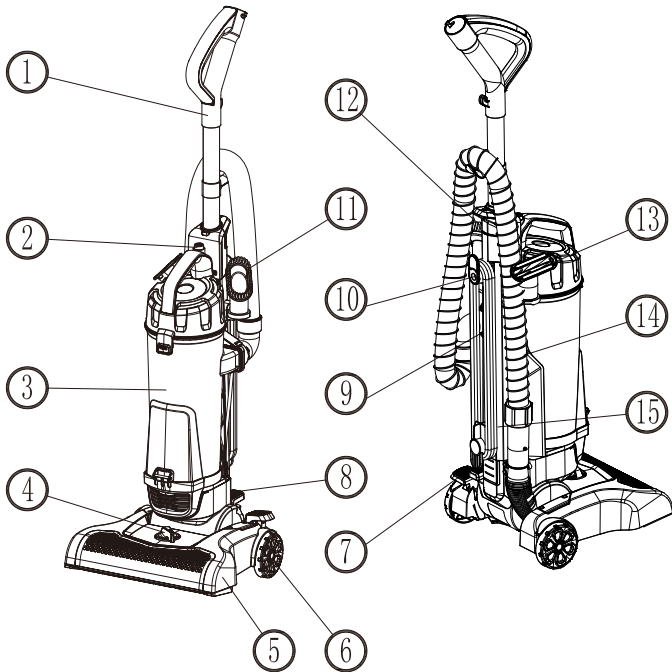

- 1. Handle
- 2. Dust Container Clamp
- 3. Dust Container Assembly
- 4. Height adjustment Button
- 5. Brush Assembly
- 6. Wheel
- 7. Cleaner Release Button
- 8. Power on/o° button

- 9. Crevice Tool
- 10. Power Cord Holder
- 11. Brush Tool
- 12. Handle Clamp
- 13. Upholstery tool
- 14. Handle Hose
- 15. Power Cord

Or by calling one of our experts on **0345 604 0105**

If you require any technical guidance or find that your product is not operating as intended, a simple solution can often be found in the **Troubleshooting** section of these instructions

## Assembling your vacuum cleaner

3



# Assembling your vacuum

Bringing it all together

## Assembly

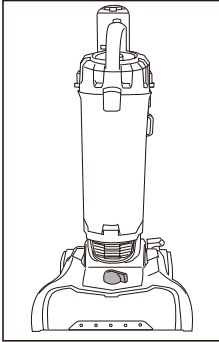

Vacuum cleaner with dust cup.

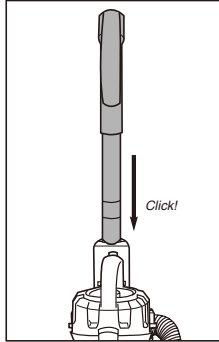

Slide handle into top of vacuum cleaner. Push down until it clicks.

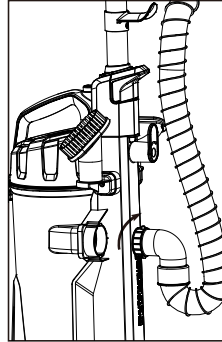

Line up the dust container with the hose attachment facing downwards, twist hose collar clockwise to secure.

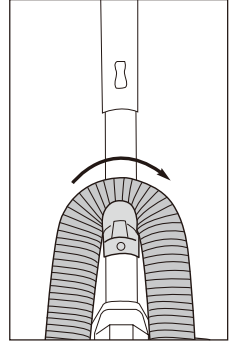

Loop hose over hose retainer.

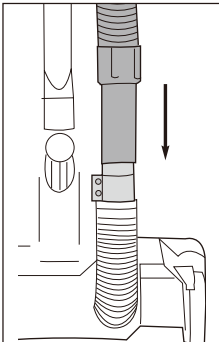

Push loose end of hose securely onto hose inlet.

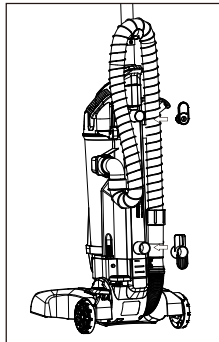

Align upper and lower cord hooks and press to snap in place. Upper cord hook should rotate freely.

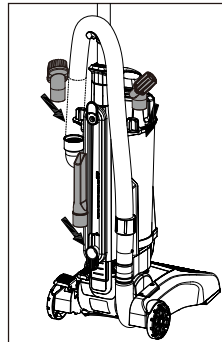

Store accessories on back of vacuum cleaner.

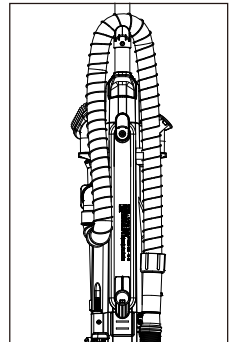

Wrap cord onto upper and lower cord hooks.



# Using your vacuum 4



# Using your vacuum

Let's get started

## Operating the appliance

Put plug into power socket

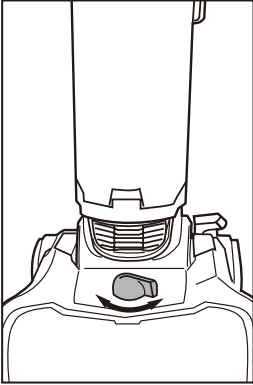

Turn height adjustment knob to adjust from Low to high pile carpet or hard floor setting as appropriate.

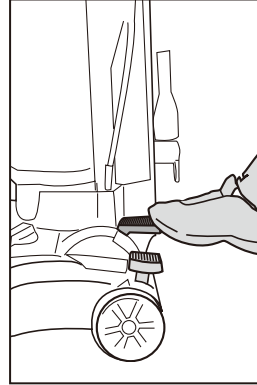

Step on power on/off button to turn vacuum cleaner on. Step on again to turn off.

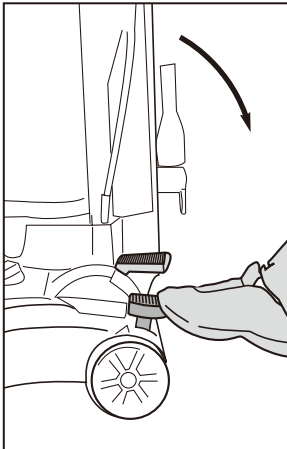

Step on cleaner release button to lower handle into position for vacuuming floors.

### Empty dust container after every use

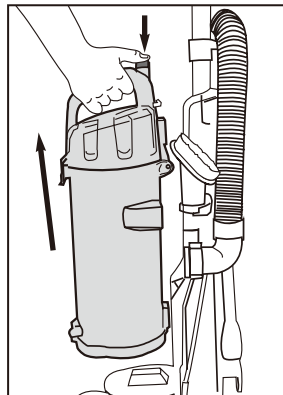

Press release button and lift dust container.

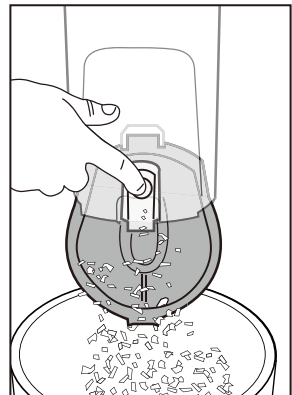

To empty debris, press lever to release bottom lid.

If you require any technical guidance or find that your product is not operating as intended, a simple solution can often be found in the

**Troubleshooting** section of these instructions

# Using your vacuum

Let's get started

## How to use accessories

**⚠ Caution:** When using tools, always place handle in upright position. Make sure vacuum cleaner is turned off while attaching tools.

1. Place vacuum in upright position.
2. Turn height adjustment knob to highest position.
3. Pull up on hose connection to release hose end from hose inlet (Fig.1).
4. Push end of hose into top of handle and twist clockwise until it clicks (Fig.2).
5. Press handle release latch and pull out handle with wand (Fig.3).
6. To attach accessories, push desired tool onto end of wand (Fig.4).
7. To use accessories without handle and wand, push desired tool directly onto end of hose (Fig.5).

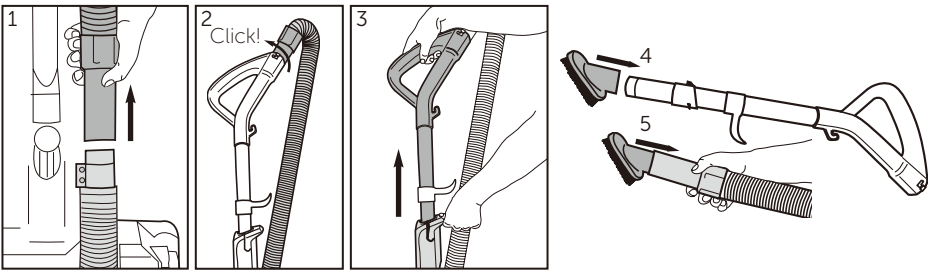

## Nozzle use

Nozzle	Cleaning area							
	Floor & carpets	Furniture	Between cushions	Curtnains	Stairs	Walls	Skirting edges	Radiators
Floor head	✓							
Brush tool		✓		✓	✓	✓		
Crevice tool		✓	✓		✓		✓	✓
Upholstery tool		✓		✓				✓

If you require any technical guidance or find that your product is not operating as intended, a simple solution can often be found in the **Troubleshooting** section of these instructions.

# Care and maintenance 5



# Care and maintenance

## Looking after your appliance

### Maintenance

Switch off and disconnect from the mains supply before carrying out cleaning and maintenance.

To ensure your vacuum cleaner works at optimum efficiency, keep the ventilation holes and vacuum cleaner surface free from dirt.

Ensure that the dust container is emptied and the air filters are washed regularly.

1. Wipe the outside of the vacuum cleaner and accessories with a damp (not wet) cloth and then wipe dry. Do not use detergents, solvents or abrasives as these may scratch or damage the surface.
2. Never immerse the vacuum cleaner, cable or plug in water.
3. When not in use, store in a cool, dry place.

### Emptying the dust container

1. When the dust container reaches the MAX line marked on the dust container or when the suction power is reduced, it is time to empty the dust container.
2. Switch off and disconnect from the mains supply.
3. To keep your vacuum cleaner running efficiently and effectively, it is recommended to empty the dust container after each use

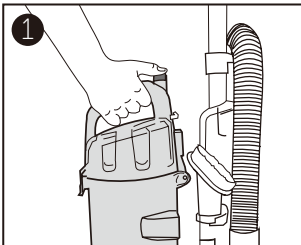

Press release button and lift off dust container.

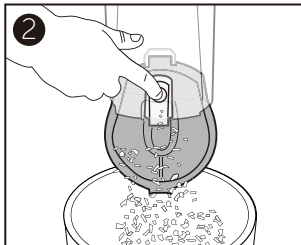

Hold dust container over wastebasket and press lever to release bottom lid.

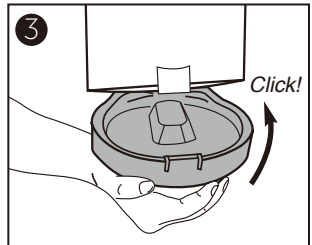

Close bottom lid until it clicks.

# Care and maintenance

## Looking after your appliance

### Cleaning the filters

1. The frequency that the filters should be cleaned will depend on appliance usage. For maximum efficiency the filter at the top of the dust container should be cleaned every time the dust container is emptied and the exhaust filter every two months. Switch off and disconnect from the mains supply.

2. Washable dust container filters – Clean monthly

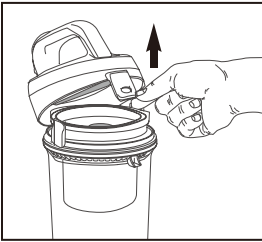

Pull dust container latch to lift up dust container lid.

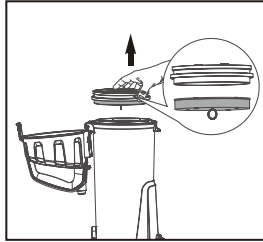

Lift out foam filter and shake off dust. Rinse foam filter and dry thoroughly.

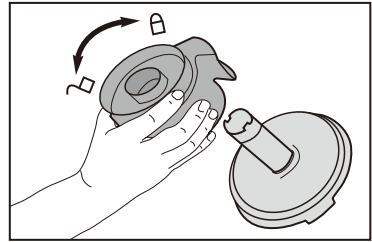

Grip tabs and lift out filter screen. Twist bottom of filter screen counterclockwise to unlock and pull apart. Shake off dust. Rinse screen and dust container. Dry all thoroughly. Reassemble screen; twist clockwise to lock.

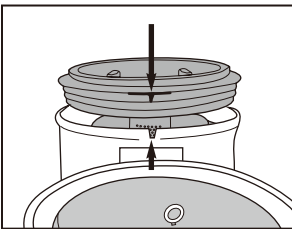

Align tab on filter screen with slot on back of dust container and drop into position.

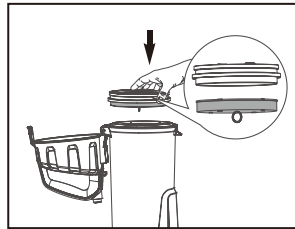

Reinstall foam filter.

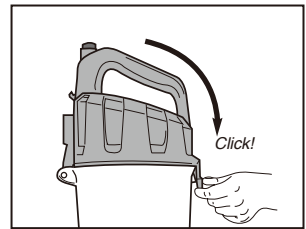

Close cover till it clicks.

**Warning:** Never operate vacuum cleaner without foam filter and filter screen in proper position.

# Care and maintenance

Looking after your appliance

## How to clear a blockage

**⚠ Caution:** Make sure vacuum is turned o° and power cord is unplugged.

If vacuum **does not pick-up** or if **the suction at end of hose is weak**, check **the air path for blockage**.

1. Press release button and lift o° dust container (Fig. 1).
2. Empty debris. Hold over wastebasket and press bottom lever to release bottom lid (Fig. 2).
3. Check filter screen. Remove any debris and shake o° dust. (See maintenance instructions on page 22.)
4. Loosen end of hose.
5. Use a rod or similar blunt implement to clear a blockage in wand or hose. Flex hose to loosen debris. (Fig. 3). Use caution if there is any sharp objects that could have become imbedded in hose.
6. Remove dust container.

**⚠ Caution:** Be careful of anything sharp that could have imbedded or got stuck in the unit when checking!

7. Use finger to check for debris in air path (Fig. 4).
8. Reinstall filters inside dust container and position dust container onto vacuum cleaner.

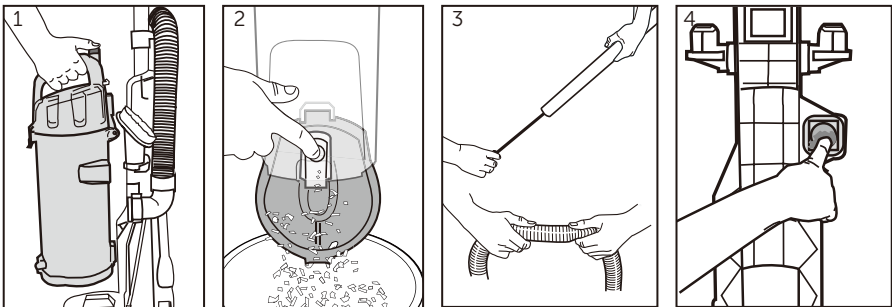

**⚠ Warning:** Never operate vacuum cleaner without foam filter and filter screen in proper position.



# Care and maintenance

Looking after your appliance

## How to maintain brush roll bar

**⚠ Caution:** Make sure vacuum is turned off and power cord is unplugged.

- Step on handle release to lower handle.
- Turn vacuum face down on floor.
- To avoid unnecessary service calls, check brush roll bar for debris.
- Use scissors to clip heavy threads or strings.
- Ensure not to cut any bristles of the bar!

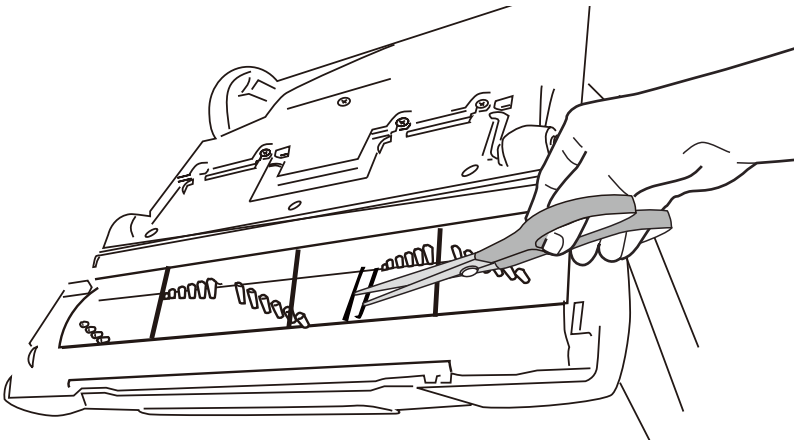
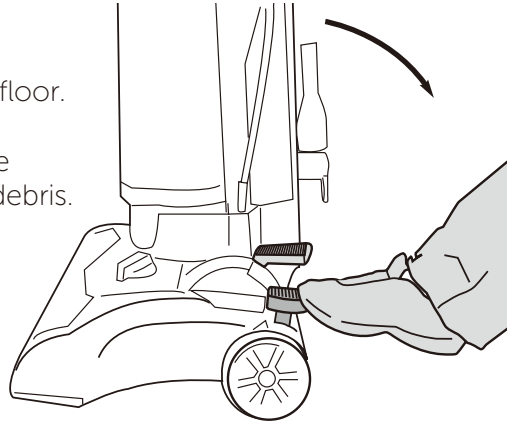

# Care and maintenance

Looking after your appliance

## How to replace brush roll bar or belt

**⚠ Caution:** Make sure vacuum is turned o° and power cord is unplugged.

- Put the product in a flat surface, with wheel face upwards
- Use a Philips screwdriver to remove 6 screws at the bottom of the base (Fig 1) lift o° brush cover
- Rotate right end of brush roll bar and lift it out, then lift out left end of brush roll bar. (Fig. 2)
- To replace belt ,position new belt around motor shaft (Fig. 3), loop new belt around brush roll bar shaft at left end of brush roll bar, then insert left end of brush roll bar first, align brush roll bar end cap with slot to make it fits into position, press right end of brush roll bar into position (Fig.4)
- Refit brush roll bar cover and screw in 6 screws (Fig 5)

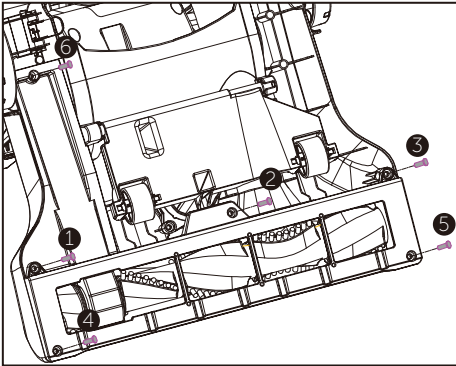

Fig 1

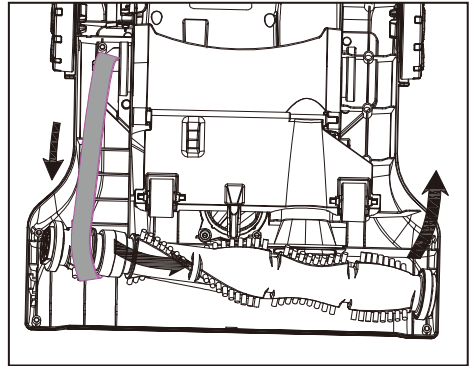

Fig 2

If you require any technical guidance or find that your product is not operating as intended, a simple solution can often be found in the **Troubleshooting** section of these instructions

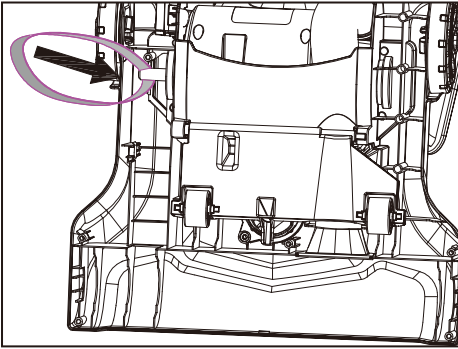

Fig 3

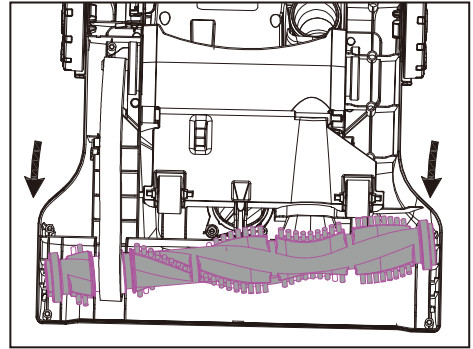

Fig 4

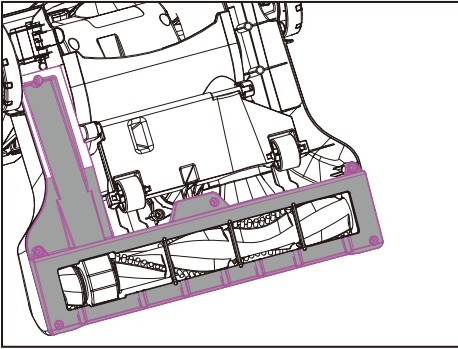

Fig 5

# Other information

## Technical Specification

Model	VUS34AE20
SKU	136566433
Cat No	3185458
Rated voltage	220-240V 50/60Hz
Power	400W
Class rating	II(double insulated)
BS 1362 fuse	13A
Capacity	4L
Noise	80 dB(A)



### Recycling electrical products



You should now recycle your waste electrical goods and in doing so help the environment.

This symbol means an electrical product should not be disposed of with normal household waste. Please ensure it is taken to a suitable facility for disposal when finished with.

Visit [www.recycle-more.co.uk](http://www.recycle-more.co.uk), click on "bank locator" and enter your postcode to find your nearest recycling site.

# Product support 6



# Product support

Help is always at hand

## TROUBLE SHOOTING

In case of malfunction, please refer to the following table.

### NOTICE: Thermal cut-off

This vacuum cleaner has a special thermostat that protects the vacuum in case of motor overheating.

**If the vacuum suddenly shuts off**, proceed as follows: 1) Push the power switch to o° and unplug the vacuum. 2) Check the vacuum for a possible source of overheating such as a full dust container, blocked hose or clogged filter. If these conditions are found, fix them and wait at least 30 minutes before attempting to use the vacuum. 3) After the 30 minute period, plug the vacuum back in and turn on the switch. If the vacuum still does not work, call the customer service helpline.

Problem	Solution
Motor will not start.	<ul style="list-style-type: none"><li>- Push plug securely into outlet, try another outlet or check circuit breaker.</li><li>- Step on power switch to turn vacuum on.</li><li>- See detailed "thermal cut-o°" instructions above.</li></ul>
Vacuum cleaner does not clean carpet.	<ul style="list-style-type: none"><li>- Empty dust container, clean and/or change filter.</li><li>- Clean or replace filter regularly to maintain suction.</li><li>- Check vacuum height adjustment knob position.</li><li>- Clean brush roll bar if needed.</li></ul>
No suction at the end of hose or wand.	<ul style="list-style-type: none"><li>- See other solutions above.</li><li>- Remove clogs from the hose or wand that restrict the airflow.</li></ul>
Burning smell; brush roll bar will not turn.	<ul style="list-style-type: none"><li>- Check brush roll bar for debris.</li><li>- Replace broken or out of shape belt.</li><li>- Refit the belt.</li></ul>
Vacuum is hard to push.	<ul style="list-style-type: none"><li>- Adjust vacuum height knob to a higher position.</li></ul>

# Product support

Help is always at hand

## Help and assistance

If you require any technical guidance or find that your Bush vacuum cleaner is not operating as intended, a simple solution can often be found in the **Troubleshooting** section of these instructions or online at [www.bush-support.co.uk](http://www.bush-support.co.uk)

If you still require further assistance, call one of our experts on 0345 604 0105\*. To help give us give you a fast and efficient service please have the following information ready:

Model Ref.

You can find this information on the rating plate – a small sticker (usually a sticker or metal plate on the rear of your product)

Serial number

Date of purchase

This will be shown on your receipt

Local call rates applies\*

Lines open 8am-7pm Monday to Saturday and 10am-4pm Sunday.

\*Calls to Bush enquiry lines may attract a charge and set up fee from residential lines depending on your call plan / tariff. Mobile and providers costs may vary, see [www.bt.com/pricing](http://www.bt.com/pricing) for details

For security and training purposes, telephone calls to and from customer service centres maybe recorded and monitored. Calls from Republic of Ireland will attract international call charges.

Or by calling one of our experts on **0345 604 0105**

# Product support

Help is always at hand

# BUSH

## Call us now and register your 12 month guarantee

Thank you for choosing Bush. Your new product is guaranteed against faults and breakdowns for 12 months. Don't forget to register it with us today so we can provide you with our best possible after-sales service and useful updates.

[www.bushregistration.co.uk](http://www.bushregistration.co.uk)

FREEPHONE\*

0800 597 8548

Lines are open 8am - 8pm, 365 days a year. \*Calls may be recorded and monitored.

### Your Bush Guarantee

This product is guaranteed for twelve months from the date of original purchase. Any defect that arises due to faulty materials or workmanship will be repaired free of charge (or if applicable the product will be replaced or the purchase price refunded) where possible during this period by the dealer from whom you purchased the unit.

The guarantee is subject to the following provisions:

- The guarantee does not cover accidental damage, misuse, cabinet parts, knobs or consumable items.
- The product must be correctly installed and operated in accordance with the instructions contained in the manual.
- It must be used solely for domestic purposes. The guarantee will be rendered invalid if the product is re-sold or has been damaged by inexpert repair.
- Specifications are subject to change without notice.
- Bush disclaim any liability for loss or damage arising from the breakdown of the product.
- This guarantee is in addition to and does not diminish your statutory or legal rights.

For your personal Guarantee Confirmation code call **0800 597 8548**  
Guarantee Confirmation Code



# Product support

Help is always at hand

## Important Data Protection Information

Bush has appointed Domestic & General Insurance PLC to provide product registration services and protection plans to accompany its products.

### What we do with your information

At Domestic & General we want to reassure you that we use your information both responsibly and securely to provide you with the best possible service. Below we explain what we do with your information and your rights to your information. If you would like any further details you can get in touch with us using the contact details below or visit our website ([www.domesticandgeneral.com](http://www.domesticandgeneral.com)).

### Using your information

Domestic & General Insurance PLC ("we") is the "data controller" of your information. We process two sets of information about you, "Personal Information" (your name, address, contact and payment details) and the "Goods Information" you provide to register your appliance or device (your name, address, contact and goods details). We'll use your information: (i) as necessary to fulfil our contract with you (including to recover any amounts owing); (ii) for our legitimate interests in: undertaking marketing (about our products and services and those of our third party partners) by post, telephone, email and/or other electronic messaging services; market research; customer surveys; printing services; checking and verifying your identity and contact details; recording your conversations for training, quality and compliance purposes; and for analytics and profiling for marketing purposes; and (iii) where required to do so by law. We may also ask for your consent to some uses of your information.

### Sharing your information

From time to time your Personal Information and Goods Information may also be shared with other members of the Domestic & General Group of Companies (Domestic & General Insurance or Services and other future members of the Group whose details we will notify to you ("Group")), with companies acting on our behalf or providing services to us (e.g. the companies we use to carry out repairs, IT & mailing services, storage of paper records and telecommunications) and with the Sainsbury's Argos Group (which currently includes Sainsbury's Supermarkets, Sainsbury's Bank, Argos Limited, Tu Clothing, Habitat, Argos Financial Services, Nectar and Insight 2 Communication, Argos Business Solutions Limited). The Sainsbury's Argos Group will process your Personal Information for their legitimate business interests (including marketing and analytics) in accordance with their privacy policy, which can be found at [www.argos.co.uk/help/privacy-policy](http://www.argos.co.uk/help/privacy-policy)

### Transferring your information

In exceptional cases, we may transfer your information to countries outside the European Economic Area (including the US) which may not have data protection laws which provide the same level of protection as provided in the UK. We have put in place Model Clauses as an appropriate safeguard to ensure that such information is adequately secured and protected and that such transfers meet the requirements of applicable data protection law.

# Product support

Help is always at hand

## Keeping your information

We keep your Personal Information for six years after you terminate your policy so that we can deal with any claims. Your goods information we keep for a bit longer, normally 10 years (the average life of an appliance) for health and safety. We also keep your information to send you marketing that you might be interested in, unless we receive a request from you to opt-out of marketing.

## Rights to your information

By writing to the Data Protection Officer using the contact details provided below, you have the right to ask us:

- for a copy of the Personal Information we hold about you
- for a copy of the Personal Information you provided to us to be sent to you or a third party in a commonly used, machine readable format
- to update or correct your Personal Information to keep it accurate
- to delete your Personal Information from our records if it is no longer needed for the original purpose; and
- to restrict the processing of your Personal Information in certain circumstances

And you may also:

- object to us processing your Personal Information – in which case we will either agree to stop processing or explain why we're unable to; and
- where we rely on your consent, withdraw that consent at any time.

Please note that the above rights are not absolute and certain exemptions apply to them. You can also make a complaint to the Information Commissioner ([www.ico.org.uk](http://www.ico.org.uk)) if you feel your Personal Information has been mishandled.

## Marketing

We, along with other members of our Group, Argos Limited, and other members of the J Sainsbury's Group of Companies may use your information to tell you about any offers, products or services which may be of interest to you. We may contact you by post, telephone, email and/or other electronic messaging services. To change your marketing preference, let us know by emailing [marketingpreferences@domesticandgeneral.com](mailto:marketingpreferences@domesticandgeneral.com) or by writing to us using the contact details provided below. If you don't want Argos to send you marketing by phone, email or post then please see Argos's Privacy Policy, which can be found on their website at [www.argos.co.uk/help/privacy-policy](http://www.argos.co.uk/help/privacy-policy) to opt out of this marketing. Argos will stop sending you marketing communications but will still contact you with service-related messages every now and then.

## Contact Details

If you need to contact us about your information or your information rights, or to see a copy of our Model Clauses, please write to: Freepost Plus RTKS-CLRA-GRYE, Data Protection Officer, Domestic & General, Leicester House, 17 Leicester Street, Bedworth, CV12 8JP or [dataprotection@domesticandgeneral.com](mailto:dataprotection@domesticandgeneral.com) and we'll be happy to help you.

Or by calling one of our experts on **0345 604 0105**

# BUSH

Should you require any guidance;  
call our Help line on 0345 604 0105.  
Further contact details can be found online at:  
[www.bush-support.co.uk](http://www.bush-support.co.uk)

Produced in China for Argos Limited and Sainsbury's Supermarkets Ltd,  
London EC1N 2HT,UK. Argos (N.I.) Ltd and Sainsbury's(NI) Ltd, Forestside  
Shopping Centre,Upper Galwally,Belfast,BT8 6FX,UK

**Bush is a registered trademark of Argos Ltd.**