

X **HOVER-1™** **GO-KART**
ELECTRIC SCOOTER ACCESSORY

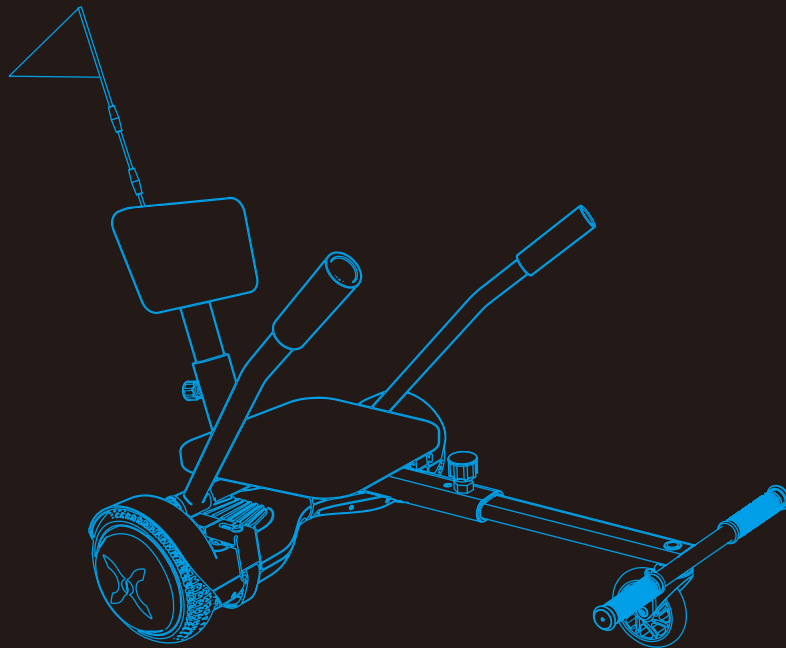

HOVER-1™ GO-KART

ELECTRIC SCOOTER ACCESSORY



Operation Manual HY-ALL-CMB Go-Kart
IMPORTANT: KEEP FOR FUTURE REFERENCE

**Images used in this manual may vary slightly from the product and are for reference purposes only.*



Even if you have ridden a scooter for years, it is important for you and every rider to read this manual before using this product.

 **WARNING**

HELMETS SAVE LIVES!

Always wear a properly fitted helmet that complies with CPSC or CE safety standards when you ride your scooter.

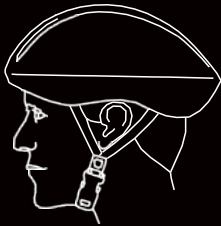

Correct Fitting:
Make sure your helmet
covers your forehead.

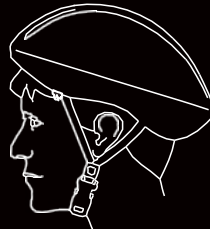

Incorrect Fitting:
Forehead is exposed and
vulnerable to serious injury.

INTRODUCTION

This manual is designed to give you the information you need for the safe operation and maintenance of your new Hover-1 Go-Kart. Please read it thoroughly before riding your Hover-1 Go-Kart.

WARNING

Make sure you read this complete manual before riding your Hover-1 Go-Kart. Failure to do so, or failure to follow its guidelines could lead to serious injury or death.

- Section One of this manual involves safety and Hover-1 Go-Kart care. Understanding and following this Information will help you and your Hover-1 Go-Kart avoid injury or damage.
- Section Two of this manual gives assembly and installation instructions for your Hover-1 Go-Kart.
- Section Three of this manual covers specific safety and operating instructions for your Hover-1 Go-Kart. Even if you are an experienced rider, you should review this section before your first ride.
- Section Four of this manual covers warranty specifications of your Hover-1 Kart.

HOVER-1 GO-KART DIAGRAM

1. Adjustable Seat
2. Handle Bars
3. Pedal Mounts
4. Elastic Strap
5. Seat Frame
6. Twist Knob
7. Frame Extension
8. Foot Rests
9. Caster Wheel
10. Flag

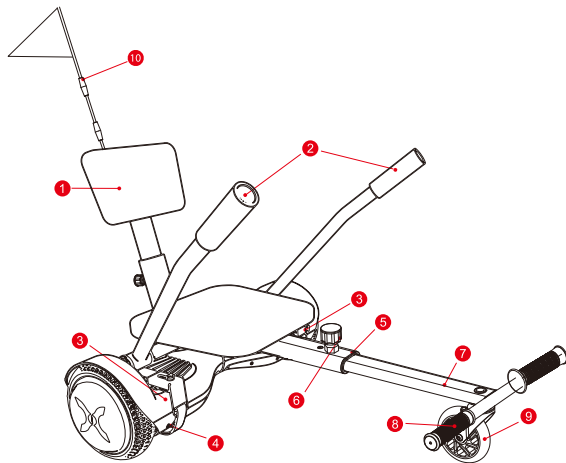







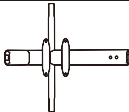
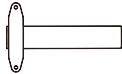
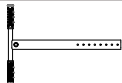
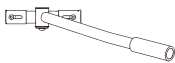
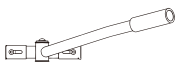

SPECIFICATIONS

Compatibility:
Max Load:
Tire Size:
Seat Material:

Most 6.5" scooters
See max load of your scooter
4" swivel caster
PP

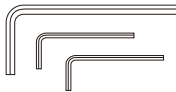
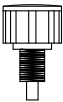
PARTS LIST

	(1) Seat Base
	(1) Seat Back
	(1) Seat Frame
	(1) Seat Back Frame
	(1) Frame extension
	(1) Right Handle Bar
	(1) Left Handle Bar

	(2) Elastic strap (4) Spare Elastic straps
	Allen Wrench Set: (2) 5mm wheel change (1) 6mm seat frame assembly
	(2) Twist Knob
	(6) Small Screws
	(2) Large Screws
	(2) Large Washers
	(1) Flag Set

ASSEMBLING YOUR HOVER-1 GO-KART

If you have questions or concerns about any of these steps, please feel free to contact our Customer Service Team at www.hover-1.com. Someone will be in touch to walk you through these steps.

Carefully follow the steps shown on the following pages for assembling the Hover-1 Go-Kart.

Remove all Hover-1 Go-Kart contents from the box. Ensure all contents from the "Parts List" section are accounted for.

1. Using the two large screws and two large washers. Attach the handle bars to the appropriate sides of the seat frame as shown below. Tighten with included 6mm Allen wrench.

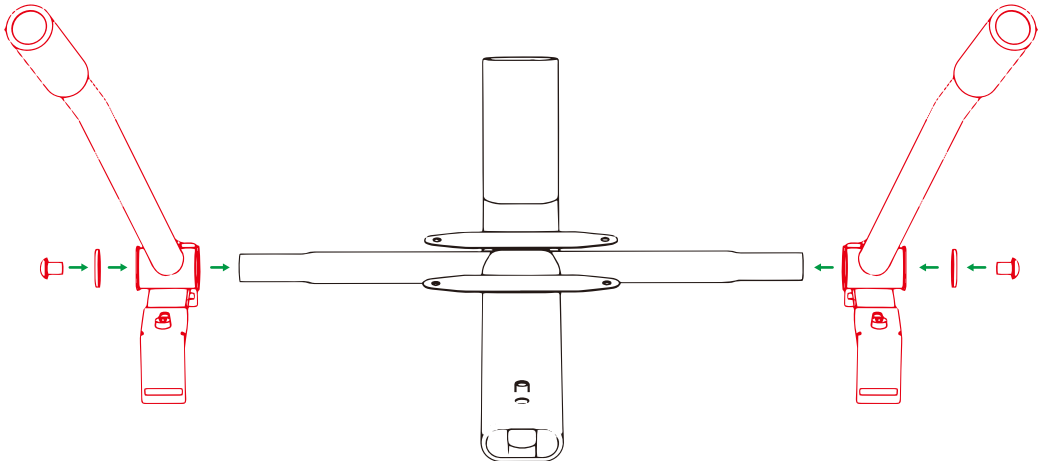

2. Align the holes of the seat with the seat frame. Secure the seat in place using the included Allen wrench, four small screws.

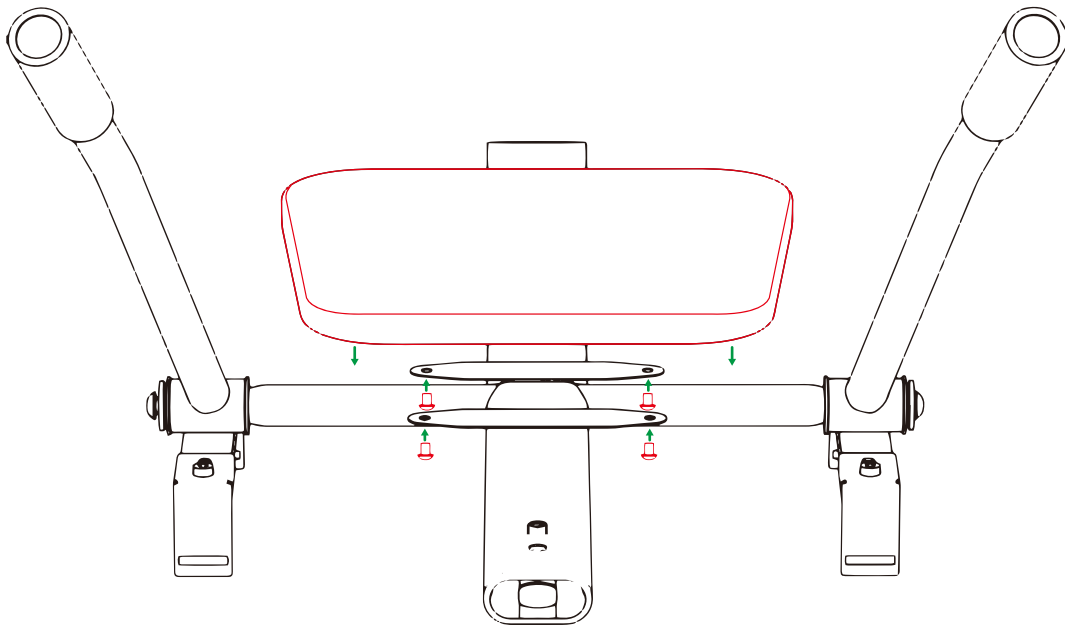

3. Insert the frame extension into the seat frame. Adjust to preferred length. Secure the frame extension in place using one twist knob.

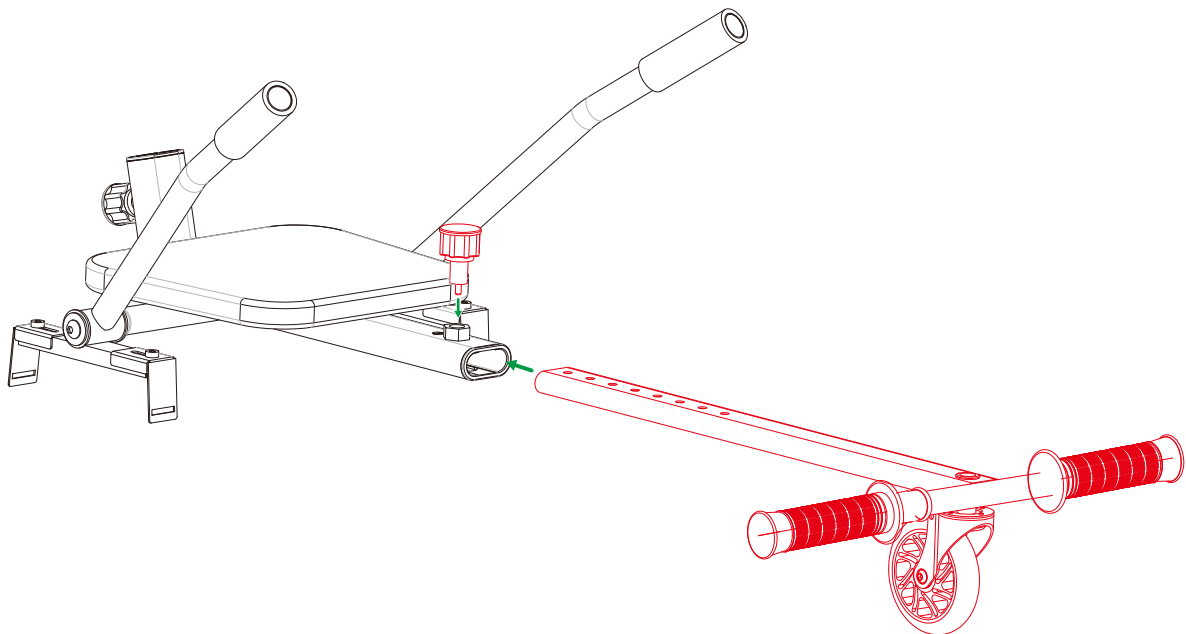

4. Align the holes of the seat back with the seat back frame. Secure the seat back in place using the included Allen wrench and two small screws.

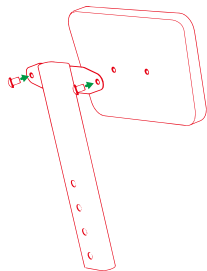

5. Insert the seat back frame into the seat frame. Adjust to preferred length. Secure the seat back frame in place using one twist knob.

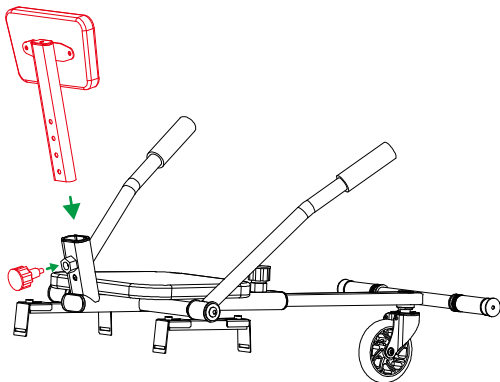

6. Your Hover-1 Go-Kart is now completely assembled and should look like the below image.

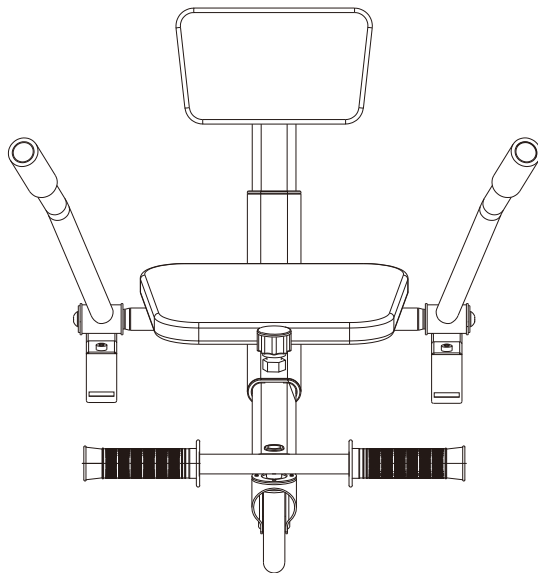

INSTALLING YOUR HOVER-1 GO-KART

If you have questions or concerns about any of these steps, please feel free to contact our Customer Service Team at www.hover-1.com. Someone will be in touch to walk you through these steps.

Carefully follow the steps shown on the following pages for installing the Hover-1 Go-Kart onto your electric scooter. Read the remainder of this manual before riding your Hover-1 Go-Kart.

Your Hover-1 Go-Kart should be completely assembled prior to installing it onto your electric scooter. Please refer to the "Assembling your Hover-1 Go-Kart" section for assembling procedures.

1. Place the pedal mounts onto the footpad sensors of your self-balancing scooter with the front wheel facing forward. Ensure the pedal mounts are centered on the footpad sensors of your scooter as much as possible.

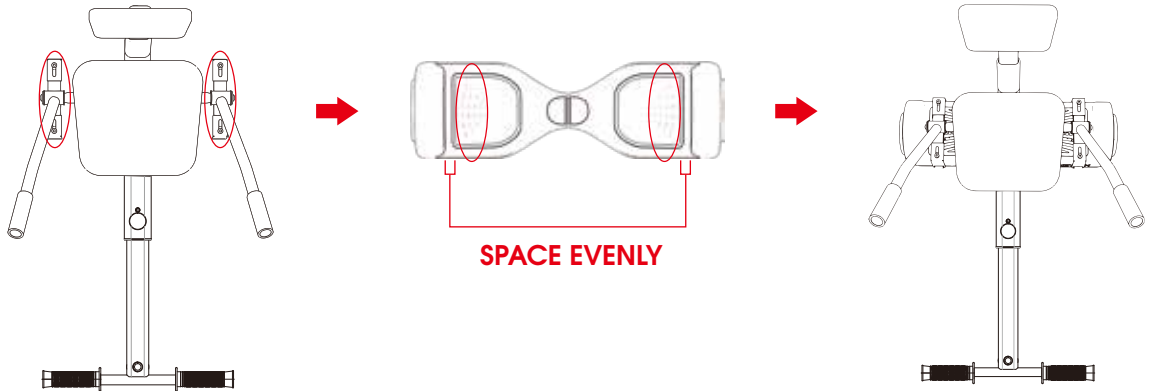

2. Using two elastic straps. Attach one end of each strap to the hooks on front of each pedal mount.

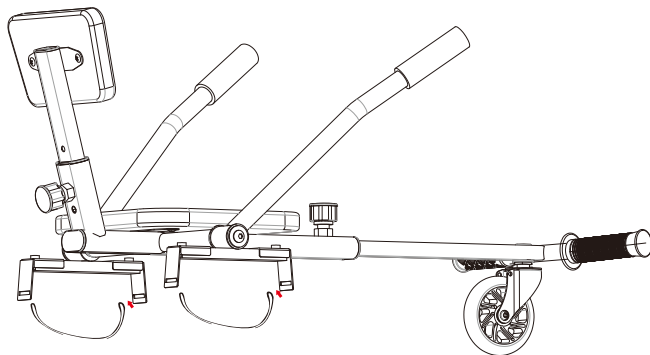

3. Wrap both elastic straps under your self-balancing scooter and attach the ends to the hooks on back of each pedal mount.

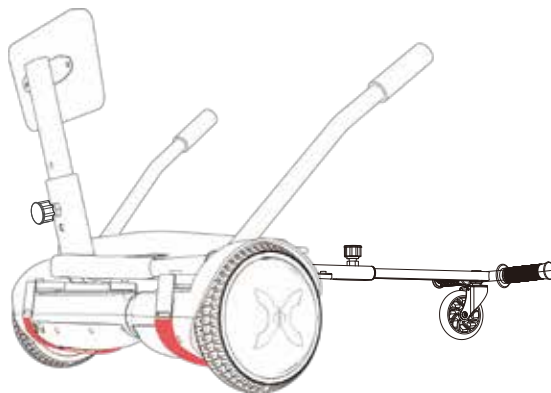
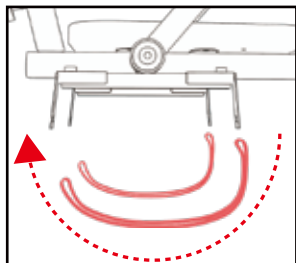

4. **WARNING:** Do not overtighten straps when you are assembling your go-kart to your scooter. Ensure that the go-kart is secure to the scooter when attaching. Ensure the foam pads are attached to the bottom of the pedal mounts so that the go-kart does not touch the footpad sensors on the scooter. See below diagram for correct fitting.

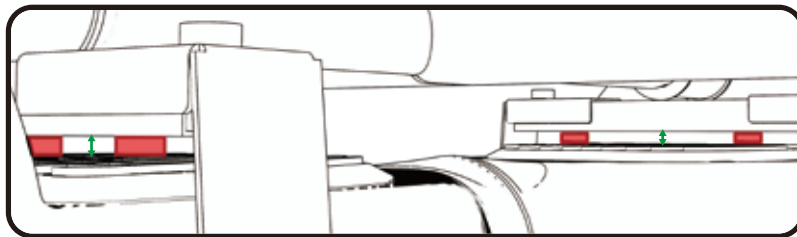

5. Your Hover-1 Go-Kart should be properly installed onto your scooter as shown below.

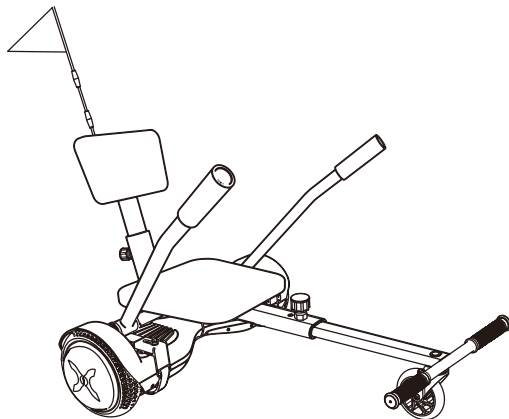

BEFORE RIDING

WARNING

Any scooter that does not work properly can cause you to lose control and fall. Inspect the entire device thoroughly before every ride, and do not ride it until any problems have been corrected.

HOVER-1 GO-KART OPERATION

It is important that you fully understand all elements of your Hover-1 Go-Kart. If these elements are not used correctly, you will not have full control of your Hover-1 Go-Kart. Before you ride fast, or outside of a controlled environment, learn the functions of the various mechanisms on your Hover-1 Go-Kart.

Practice using the elements of your Hover-1 Go-Kart at slower speeds in a flat, open area before taking the Hover-1 Go-Kart to unfamiliar areas.

WARNING

Do not ride a Hover-1 Go-Kart with a part that is damaged; replace the damaged part before riding.

PRE-RIDE HOVER-1 GO-KART CHECKLIST

Ensure that your Hover-1 Go-Kart and scooter are in proper working order each and every time you ride. If a part of the Hover-1 Go-Kart does not function correctly, please contact our Customer Support Center.

- Ensure the battery of your scooter is fully charged before riding your Hover-1 Go-Kart.
- Ensure that the screws on the Hover-1 Go-Kart are tightly secured before each ride.
- Check to ensure the tires of your scooter are not worn.
- Check to ensure all connections are maintained on your scooter.

SAFETY PRECAUTIONS

The first rule in safe riding is to use common sense. A Hover-1 Go-Kart is vulnerable; it cannot protect you in a crash, against impact, or loss of control the way driving a car can. A Hover-1 Go-Kart can tip over sideways or pitch you over the front wheel. It moves faster than a typical scooter. It does not have bumpers or airbags as a car does. This section is a guide of safe riding practices for operation. Make sure you are using your Hover-1 Go-Kart properly.

Different localities and countries have different laws governing riding on public roads, and you should check with local officials to ensure you are complying with these laws.

Hover-1 is not liable for tickets or violations given to riders who do not follow these regulations.

- For your safety, always wear a helmet that meets CPSC or CE safety standards. In the event of an accident, a helmet can protect you from serious injury and in some cases, even death.
- Obey all local laws, stop signs, pedestrian crosswalks, etc.
- If riding with friends and multiple Hover-1 Go-Karts, ride single file in a straight line.
- Have a satisfactory signaling device (bell, horn, etc.) to warn drivers and pedestrians of your approach.
- Ride defensively; expect the unexpected.
- Give pedestrians the right-of-way.
- Do not ride too close to pedestrians and alert them if you intend to pass them from behind.

- Slow down at all street intersections and look to the left and right before crossing.
- Obey all traffic signals.
- Always use proper hand signals for turning and stopping. Give signals 100ft before stopping or turning and always return both hands to the handle bars before stopping or turning.
- Watch for cars pulling out into traffic and for the sudden opening of car doors.
- Avoid potholes, drainage grates or other hazards.
- Be careful when riding on soft road edges, gravel, sand and uneven surfaces. Ride slowly and avoid quick turns when riding on these surfaces.
- Never hitch onto other vehicles.
- Do not "stunt" ride or race in traffic.
- Do not weave in and out of traffic or swerve from side to side.
- A crash can put extraordinary stress on Hover-1 Go-Kart components, possibly causing them to fatigue prematurely. Components suffering from stress fatigue can fail suddenly, causing loss of control or serious injury.

CAUTION: RIDING IN WET WEATHER

Brakes do not work as well under wet conditions as they do when dry. It is recommended that you do not ride your Hover-1 Go-Kart in wet weather, as there are electronic components of scooter that may be damaged if exposed to water.

1. This product is strictly forbidden to use on roads and highways, unless your local laws state otherwise. You must wear a safety helmet, knee and elbow pads and other necessary protective gear when riding your Hover-1 Go-Kart.
2. Due to the particularity of the product, the assembly pieces are to be checked before every ride to avoid an accident while riding.
3. Do not make a sharp turns as you may drift and overturn the Hover-1 Go-Kart which can result in injury to yourself and/or damage the unit.
4. Do not operate near swimming pools or other bodies of water.

 **WARNING:**

To reduce the risk of injury, adult supervision is required. Never use in roadways, near motor vehicles, on or near steep inclines or steps, swimming pools or other bodies of water; always wear shoes, and never allow more than one rider.

RIDING YOUR HOVER-1 GO-KART

Ensure your Hover-1 Go-Kart is fully assembled and correctly installed onto your scooter with all straps and screws secured in place. Ensure your scooter is properly maintained as well. Failure to do so may result in serious bodily harm or death and damage to the unit.

After reviewing the pre-ride checklist, follow the steps below to begin riding your Hover-1 Go-Kart.

1. Turn on your scooter.
2. Sit comfortably in the Hover-1 Go-Kart seat.
2. Place your feet onto the foot rests.
3. Firmly grip both handle bars and slowly push them downward simultaneously to move forward.
4. When riding, slowly pull both handle bars upwards simultaneously to brake.
5. To reverse, slowly pull both handle bars upwards simultaneously.
6. To turn left, push the right handle bar down while holding the left handle bar in neutral position.
7. To turn right, push the left handle bar down while holding the right handle bar in neutral position.

WARRANTY

For warranty information, Please visit us at:
www.hover-1.com



www.hover-1.com



@RideHover1



@RideHover1



@RideHover1