

Breville®

Turn **on** your creativity®



Halo Air 9L Digital Air Fryer

VDF131

product safety

READ CAREFULLY AND KEEP FOR FUTURE REFERENCE

This appliance can be used by children aged from 8 years and above and persons with reduced physical, sensory or mental capabilities or lack of experience and knowledge if they have been given supervision or instruction concerning use of the appliance in a safe way and understand the hazards involved.

Children shall not play with the appliance.

Cleaning and user maintenance shall not be made by children unless they are older than 8 and supervised.

Keep the appliance and its cord out of reach of children less than 8 years.

This product must be positioned on a stable surface with the handles positioned to avoid the spillage of hot liquids.

 Surfaces of the product are liable to get hot during use.

Never operate the product by means of an external timer or separate remote-control system.

Never immerse any part of the appliance or power cord and plug in water or any other liquid.

If the supply cord is damaged, it must be replaced by the manufacturer, its service agent or similarly qualified persons in order to avoid a hazard.

Ensure the appliance is kept clean after use. For details see the Care and Cleaning section. Pay particular care regarding items that can be immersed in water and/or a dishwasher.

- ⚠ Never use this appliance for anything other than its intended use. This appliance is for household use only. Do not use this appliance outdoors.
- ⚠ Always ensure that hands are dry before handling the plug or switching on the appliance.
- ⚠ Always use the appliance on a stable, secure, dry and level surface.
- ⚠ Ensure the appliance is switched off and unplugged from the supply socket if it is left unattended, when it is not in use or before cleaning. Never leave the appliance unattended when it is in use.
- ⚠ Never use this appliance with an external timer or separate remote-control system.
- ⚠ Always allow the appliance to fully cool down before cleaning or storing.
- ⚠ Do not use the appliance if it has been dropped, if there are any visible signs of damage or if it is leaking.
- ⚠ Never let the power cord hang over the edge of a work top, touch hot surfaces or become knotted, trapped or pinched.
- ⚠ Do not touch the external surfaces of the appliance during use as they may become very hot.
- ⚠ Only use spares or accessories that are recommended by the manufacturer.
- ⚠ Allow adequate space above and on all sides for air circulation.
- ⚠ Do not allow the appliance to touch any flammable material during use (such as curtains or wall coverings).
- ⚠ Care is required when using the appliance on surfaces that may be damaged by heat. The use of an insulated pad is recommended.

Parts

1. Air flow vent (intake)
2. Control panel
3. Cooking drawer
4. Non-stick coated air fryer tray
5. Handle
6. Air flow vent (outlet)
7. Power cord storage

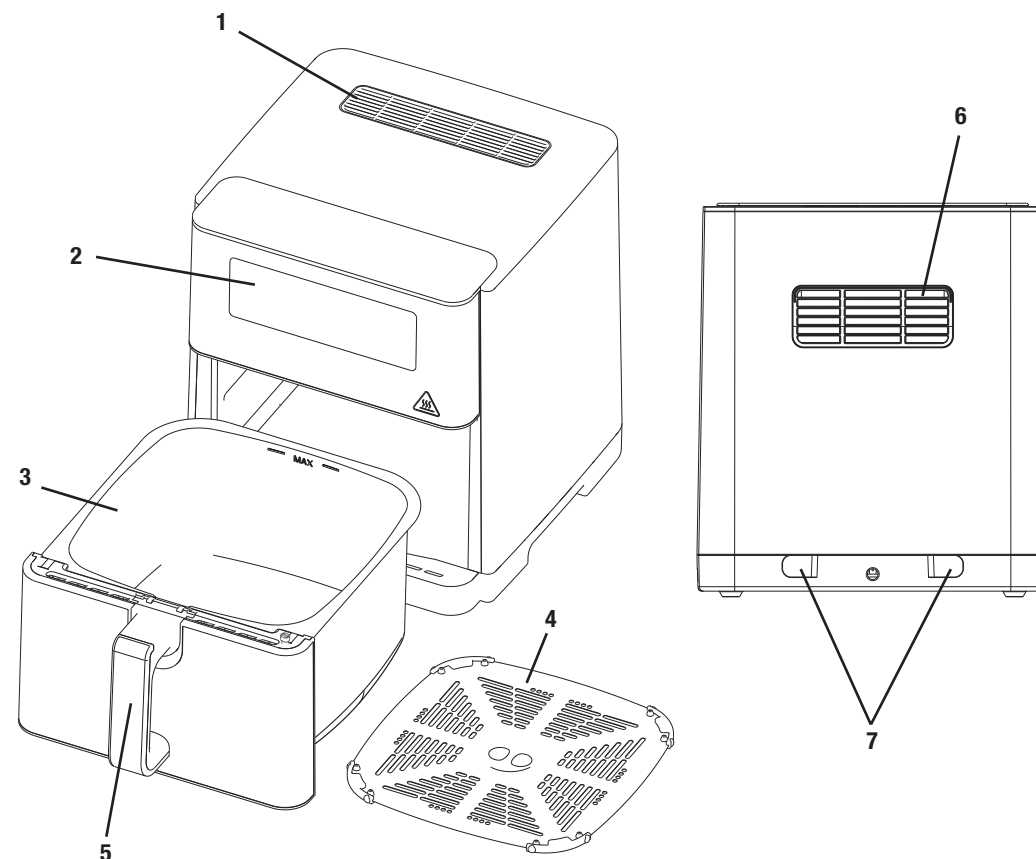

Control Panel

8. Power
9. Temperature setting
10. Timer setting
11. Start/ stop
12. Presets setting

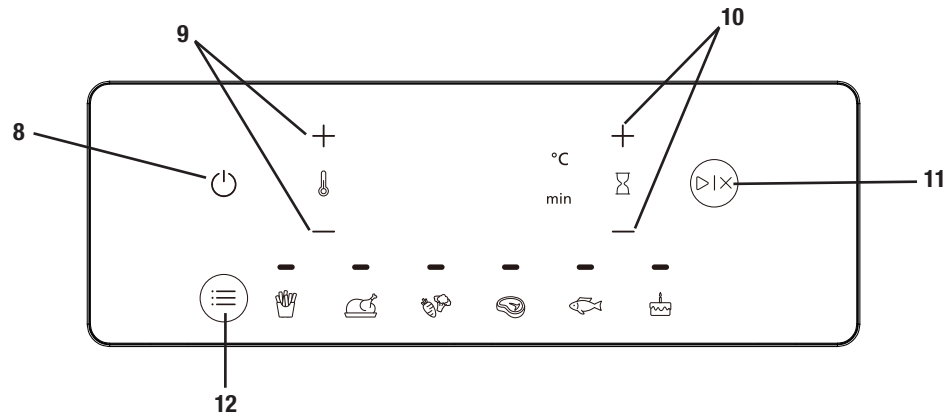

Preset Chart

Presets	Temp.	Time
Fries	200°C	18mins.
Chicken	200°C	22mins.
Vegetables	180°C	10mins.
Steak	200°C	15mins.
Fish	180°C	12mins.
Bake	160°C	12mins.

Usage Instructions

Preparing Your Air Fryer For First Use

1. Remove all packaging materials, stickers and labels in and on the unit.
2. Clean interior basket and tray of the Air Fryer wipe with a damp cloth using only mild, soapy water. DO NOT IMMERSE IN WATER. Abrasive cleaners, scrubbing brushes and chemical cleaners will damage the unit.
3. Place unit on a flat surface.
4. Plug the air fryer into an electrical outlet.
5. Press the Power button (⏻) the unit turns on.
6. Select any preset cooking mode for approximately 15 minutes to eliminate any manufacturing residue that may remain.

Preset Mode

1. Place unit on a flat surface.
2. Plug the air fryer into an electrical outlet.
3. Place the air fryer tray in the bottom of the air fryer drawer.
4. Add food into air fryer tray and insert the air fryer drawer back into the air fryer.
5. Press Power button (⏻) the unit turns on.
6. Choose the desired Preset – Fries, Chicken, Vegetables, Steak, Fish or Bake. Temperature and time will automatically appear.
NOTE: The preset temperature and timer are guidance only, please see Air Fryer Cooking Chart for details. To adjust temperature and time use the plus and minus signs next to the temperature (🌡) and time (⌚) symbol.
7. Press Start (>|X) for Air Fryer to start.
8. Audible alert will sound once timer is done. Carefully remove air fryer drawer and the food with a heat safe cooking utensil. Do not put it on a surface which it is not heatproof. Do not tip the basket to remove food.
NOTE: To pause cooking cycle open the air fryer drawer, the cooking cycle will continue when drawer is reinserted. To stop cooking cycle press Start/Stop (>|X).

Cleaning & Maintenance For Your Air Fryer

1. Clean the Air Fryer and accessories after each use.
2. Before cleaning your Breville® Air Fryer, unplug it and allow it to cool.
3. To clean interior of the Air Fryer wipe with a damp cloth using only mild, soapy water. DO NOT IMMERSE IN WATER. Abrasive cleaners, scrubbing brushes and chemical cleaners will damage the unit.
4. Empty the air fryer drawer and tray frequently to avoid accumulation of crumbs.
5. Fryer drawer and tray are dishwasher safe.

Air Fryer Cooking Chart

Food	Weight	Function	Time	Temperature	Shake/Turn half way through cooking	Oil
POTATOES						
Hand Cut Fries	500g - 700g	Fries	25 - 30 mins	200°C	Yes	1 tbsp
Hand Cut Fries	250g	Fries	12 - 15 mins	200°C	Yes	½ tbsp
Frozen Fries, (Thick Cut)	500g – 700g	Fries	20 - 25 mins	200°C	Yes	No
Frozen Fries, (Thick Cut)	250g	Fries	13 – 15 mins	200°C	Yes	No
Frozen Fries, (Thin Cut)	500g – 700g	Fries	18 - 20 mins	200°C	Yes	No
Frozen Fries, (Thin Cut)	250g	Fries	10 – 12 mins	200°C	Yes	No
Frozen Sweet Potato fries	500g	Fries	12 - 15 mins	200°C	Yes	No
Frozen Hash Browns	600g	Fries	18 - 20 mins	200°C	Yes	No
Fresh Jacket Potatoes	1kg (4)	Manual	60 mins	180°C	No	½ tbsp
MEAT/POULTRY/FISH						
Steak	250g (1)	Meat	10 - 15 mins	200°C	Yes	½ tbsp
Pork Chops	600g (3)	Meat	15 - 20 mins	180°C	Yes	1 tbsp
Beef Burgers	340g (2)	Meat	16 - 18 mins	180°C	Yes	½ tbsp
Whole Roast Chicken	1.8kg – 2.2kg	Chicken	80 – 90 mins	170°C	No	1 tbsp
Whole Roast Chicken	1.3kg – 1.6kg	Chicken	60 - 70 mins	170°C	No	1 tbsp
Chicken Wings	1 kg	Chicken	30 - 35 mins	180°C	Yes	No
Salmon Fillet	480g (2)	Fish	12 – 15 mins	180°C	No	No
FROZEN FOODS						
Frozen Battered Fish	400g (2)	Fish	12 – 15 mins	180°C	Yes	No
Frozen Chicken Nuggets	400g	Chicken	12 – 15 mins	180°C	Yes	No
Frozen Vegetable Burgers	450g (4)	Vegetables	15 - 20 mins	200°C	Yes	No
Frozen garlic bread slices	6 slices	Manual	10 mins	180°C	Yes	No
VEGETABLES						
Frozen Onion Rings	400g	Vegetables	12 – 15 mins	200°C	Yes	No
Fresh Roasting Vegetables	800g	Vegetables	15 - 20 mins	180°C	Yes	1 tbsp

Recipes

Whole Roast Chicken

Serves 4

Prep time 10 minutes

Cook time 60 minutes

1.3-1.6kg whole chicken
1 tbsp olive oil

1 tbsp dried oregano
Salt and pepper

Rub the chicken with the oil, coating the skin all over. Dust with the oregano and seasoning.

Place the chicken upside down onto the air fryer tray in the drawer and cook on the Chicken setting, 170°C for 60-70 minutes depending on the size of your chicken, carefully turning your chicken over, halfway through the cooking time.

Once cooked, carefully remove from the drawer and set aside to rest for 5 minutes before carving.

Takeaway Style Salt and Pepper Chicken Wings

Serves 3-4

Prep Time 20 minutes

Cook Time 40 minutes

1 kg fresh Chicken Wings
1 tsp Chinese 5 spice
1 tbsp vegetable oil
1 medium onion, diced
1 green pepper, thinly sliced

2 red chillies, thinly sliced
2 green chillies, thinly sliced
1 tsp dried chilli flakes
3 garlic cloves, finely chopped
To serve - 1 tbsp sesame oil, 3-4 spring onions sliced

For the salt and pepper seasoning

2 tbsp salt
¼ tsp freshly ground pepper

1 tbsp sugar
½ tsp Chinese 5 spice

Place the chicken wings in a large bowl, sprinkle over 1 generous tsp of Chinese 5 spice and rub well in, coating each wing with some of the seasoning.

Place into the air fryer drawer and cook at 200°C, for 35 minutes, shaking half way through cooking for even colouring.

Whilst these are cooking, combine the salt and pepper seasoning ingredients into small bowl.

Heat a suitable sized frying pan over a medium heat, add the oil, onion and green pepper and stir fry for approx. 3-5 minutes until softened.

Add the chillies, chilli flakes, and garlic and continue cooking for a further minute, remove from the heat.

Once the chicken wings have finished cooking, spoon over the cooked onion and pepper mixture and return to the air fryer, cooking for a further 5 minutes, 200°C.

Remove the wings from the drawer, dust with some of the salt and pepper seasoning and drizzle with a little sesame oil.

Serve immediately scattered with the spring onions.

Moroccan Cous Cous with Roasted Vegetables

Serves 4-6

Prep Time 20 minutes

Cook Time 15-20 minutes

1 red pepper, deseeded and cut into quarters	½ tsp ground cinnamon
1 yellow pepper, deseeded and cut into quarters	250g dried cous cous
1 large courgette, sliced	400ml boiling water
1 red onion, cut into chunks	1 tsp turmeric
4 tbsp olive oil	400g tin chickpeas, drained and rinsed
Zest and juice of 1 large lemon	75g raisins
1 large clove of garlic, finely chopped	15g roughly chopped coriander leaves
1 tsp cumin	Small handful of mint leaves, shredded
1 tsp ground coriander	

Place the peppers, courgette and red onion into a large bowl, add 1 tbsp of olive oil and mix well. Tip the vegetables into the air fryer drawer and cook for 15 - 20 minutes, 180°C, shaking half way through cooking to ensure even browning.

Whilst the vegetables are cooking, mix the remaining olive oil, lemon zest and juice, garlic, cumin, coriander and cinnamon in a small bowl and set aside.

Place the cous cous into a heatproof bowl, add the boiling water and turmeric, mix well and cover with some food wrap for approx. 5 minutes.

Remove the vegetables from the Air Fryer and allow to cool.

Once cool enough to handle cut into bite sized pieces.

Stir the lemony oil into the cous cous, along with the remaining ingredients, add the cooked vegetables, mix well and adjust the seasoning.

Will keep for approx. 2 days in a refrigerator in a covered container.

Steak with Chimichurri Dressing

Serves 2

Prep Time 15 minutes

Cook Time 10 minutes, medium rare.

For this recipe you will need a small food processor or mini chopper to prepare the chimichurri.

2 sirloin steaks approx. 225-250g weight per steak	Freshly ground black pepper
1 tsp vegetable oil	

Dressing

Small bunch parsley leaves picked	2½ tbsp extra virgin olive oil
2 garlic cloves, peeled	Juice of ½ lemon
1 shallot, quartered	2 tsp red wine vinegar
½ tsp chilli flakes	

Remove your steak from its packaging and allow to sit at room temperature for approx. 30 minutes to 1 hour before cooking.

Brush the steak both sides with the oil and add a dusting of freshly ground black pepper.

Place both steaks onto the air fryer tray in the drawer and cook for 10-12 minutes, turning half way.

Place all the dressing ingredients into your mini food processor and blend until the parsley is chopped.

Remove the steak from the air fryer place onto a warm plate and allow to rest for approx. 5 minutes.

Carve the steak on the diagonal, serving the chimichurri on the side.

Helpful Tips / Troubleshooting

PROBLEM	POTENTIAL CAUSE	SOLUTION
Overcooked / Undercooked Foods	<ul style="list-style-type: none">Incorrect temperature or time setting	<ul style="list-style-type: none">You may have to adjust the time and temperature to desired taste.Because your Air Fryer is smaller than your regular oven, it will heat up faster and generally cook in shorter periods of time.
Burning Smell	<ul style="list-style-type: none">Food build-up inside fryer drawer	<ul style="list-style-type: none">Refer to "Cleaning Your Air Fryer" Section, Page 5.
Touch panel interface is non-responsive	<ul style="list-style-type: none">Panel is dirty or greasyExcess moisture on panelController is malfunctioningFryer drawer is not inserted	<ul style="list-style-type: none">Ensure panel is clean and free of debris before using.Ensure panel is clean and dry, and use dry hands to operate.Unplug unit and let it rest for 60 seconds before plugging in again. If the error persists contact aftersales support.Ensure fryer drawer is insert correctly.
Small water drips and steam escape from drawer during cooking	<ul style="list-style-type: none">Water released from food during the cooking cycle	<ul style="list-style-type: none">This is not a concern and is part of the normal cooking cycle. Please mop up drips with a soft cloth.

Fitting of a plug - for U.K. and Ireland only

⚠ This appliance must be earthed.

If the plug is not suitable for the socket outlets in your home, it can be removed and replaced by a plug of the correct type.

If the fuse in a moulded plug needs to be changed, the fuse cover must be refitted. The appliance must not be used without the fuse cover fitted.

If the plug fuse requires replacement, a fuse of the same rating as that fitted by the manufacturer must be used. In order to prevent a hazard do not fit a fuse of a lower or higher rating.

If the terminals in the plug are not marked or if you are unsure about the installation of the plug please contact a qualified electrician.

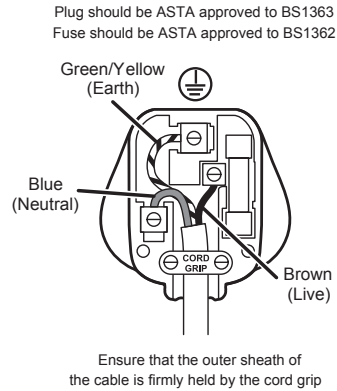

After sales service & replacement parts

In the case the appliance does not operate but is under warranty, return the product to the place it was purchased for a replacement. Please be aware that a valid form of proof of purchase will be required. For additional support, please contact our Consumer Service Department at **0800 028 7154** or email: **BrevilleEurope@newellco.com**.

Waste Disposal

Waste electrical products should not be disposed of with household waste. Please recycle where facilities exist. E-mail us at **BrevilleEurope@newellco.com** for further recycling and WEEE information.



Breville®

Newell Brands UK Limited
5400 Lakeside, Cheadle Royal Business Park,
Cheadle, SK8 3GQ, United Kingdom
Newell Poland Services Sp. z o.o.,
Plac Andersa 7, Poznan, 61-894, Poland.
e-mail: BrevilleEurope@newellco.com
Telephone: 0800 028 7154



© 2023 Newell Brands UK Limited. All rights reserved.
Newell Brands UK Limited, 5400 Lakeside, Cheadle Royal Business Park, Cheadle, Cheshire, SK8 3GQ, United Kingdom.
Newell Poland Services Sp. z o.o., Plac Andersa 7, Poznan, 61-894, Poland.
Newell Brands UK Limited and Newell Poland Services Sp. z o.o. are subsidiaries of Newell Brands Inc.
The product you buy may differ slightly from the one shown on this carton due to continuing product development.
Made in China.